

12
11
10
9
8
7
6
5
4
3
2
1
0 [cm]

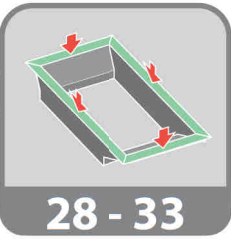

XLC-P

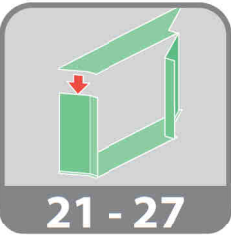
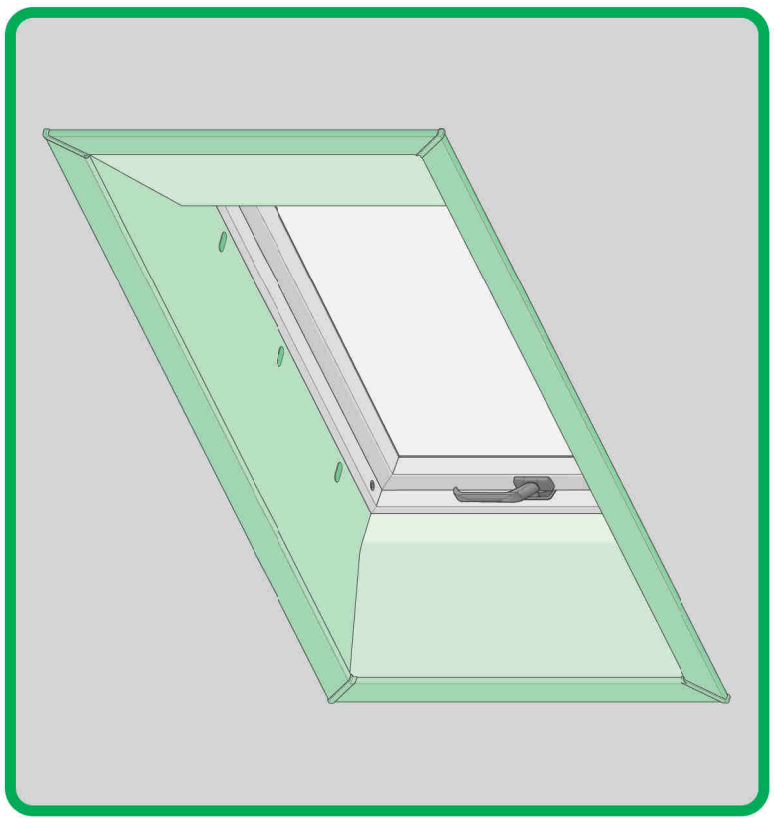

NC 9N9_XLC-P_26.04.08_FAKRO_KB-46

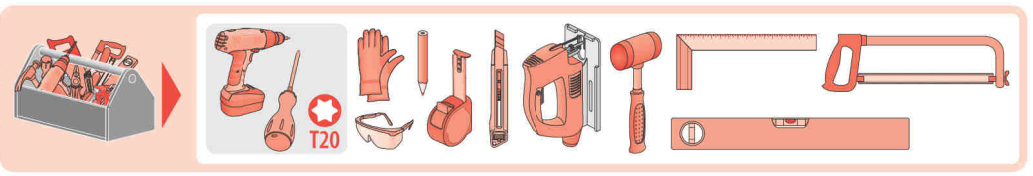

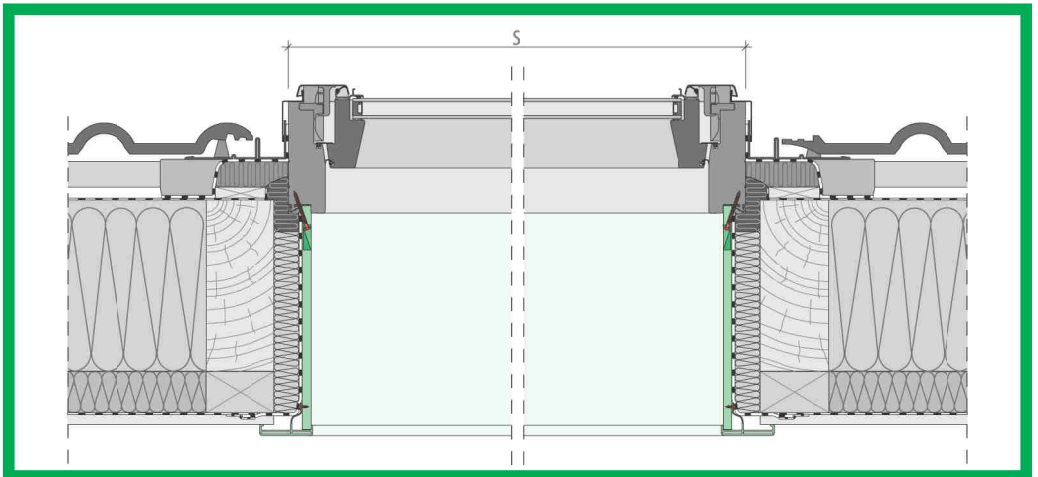
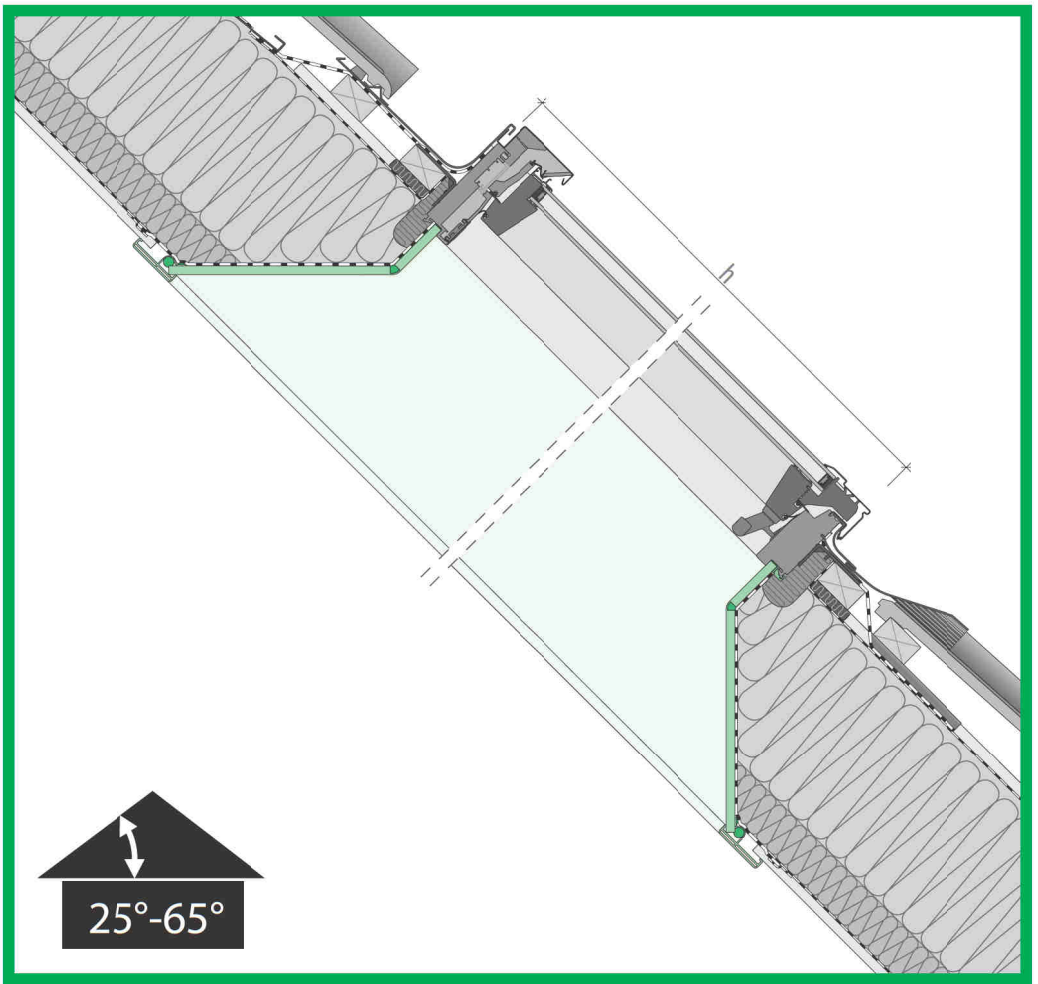

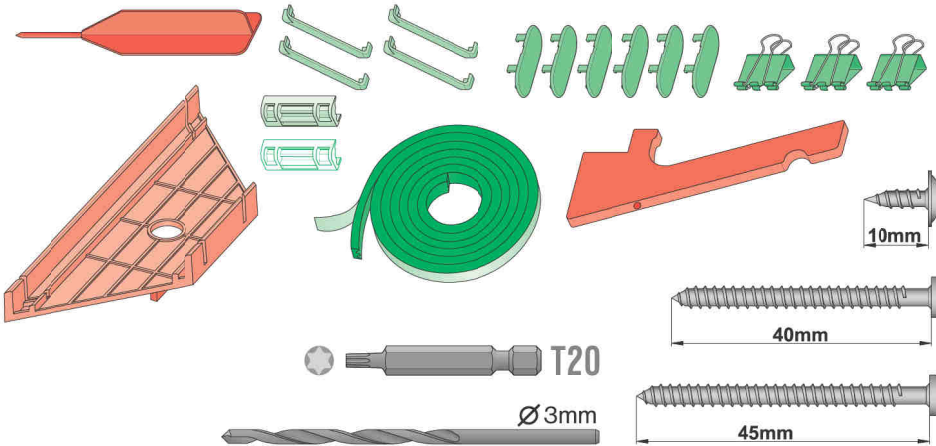
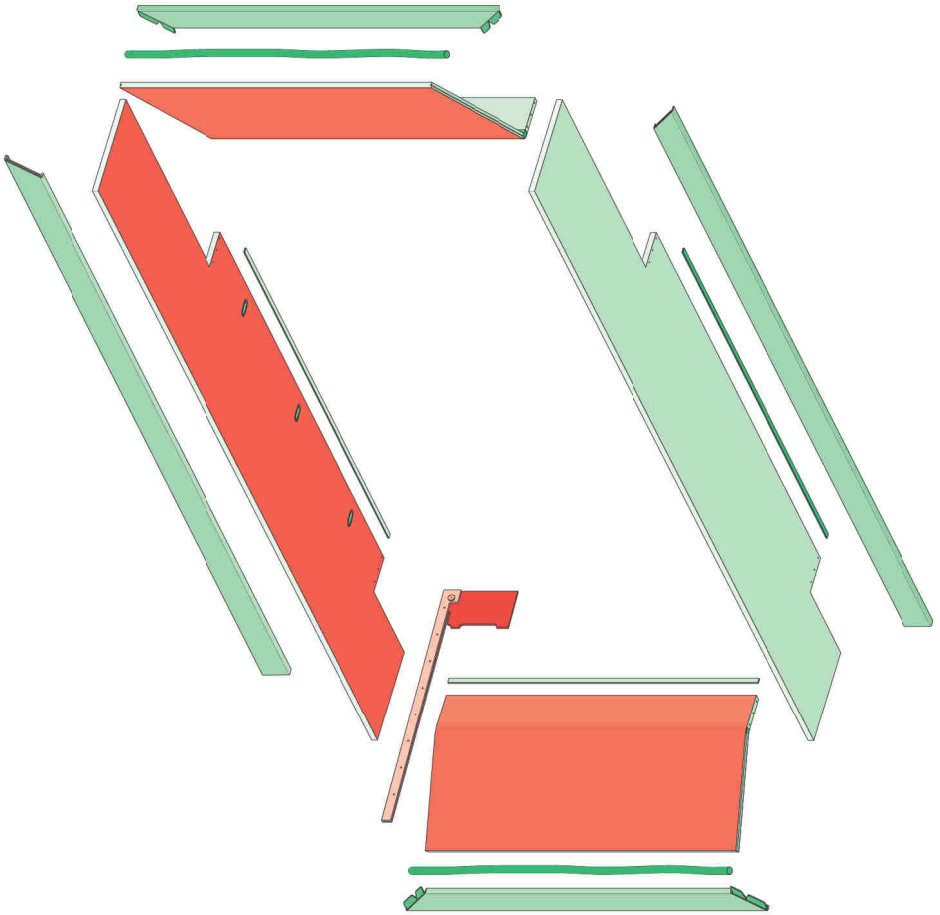

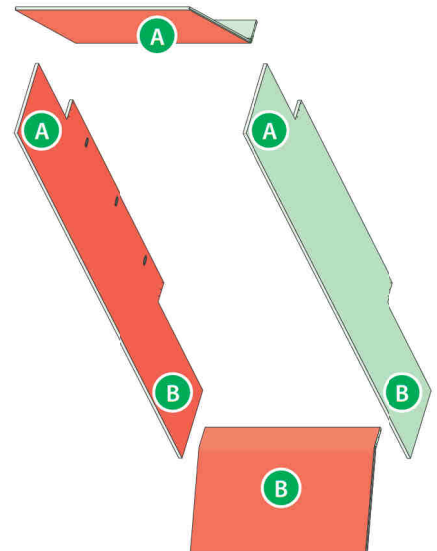
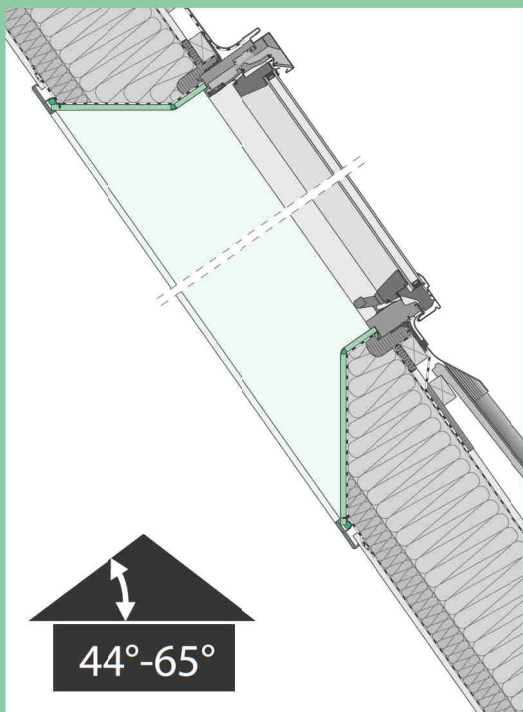
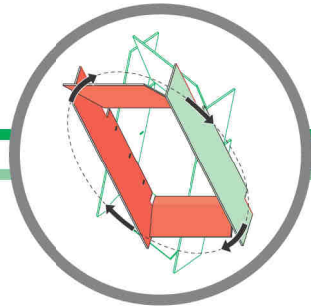
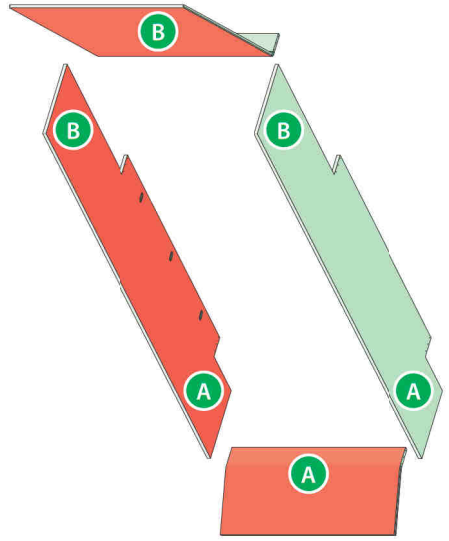
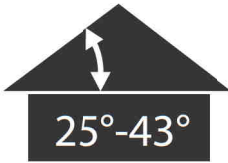
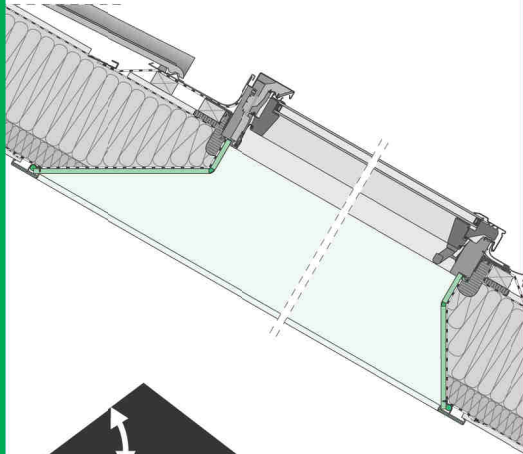

1

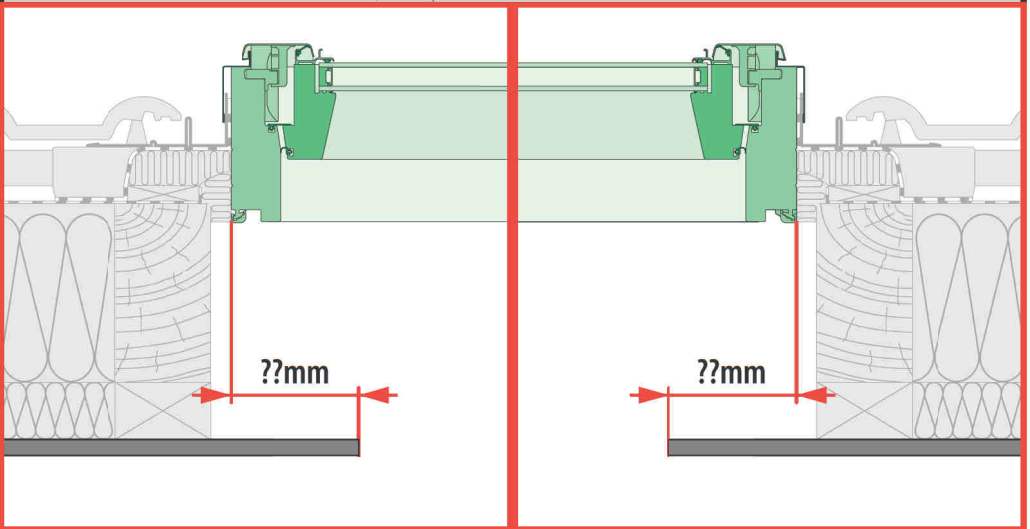
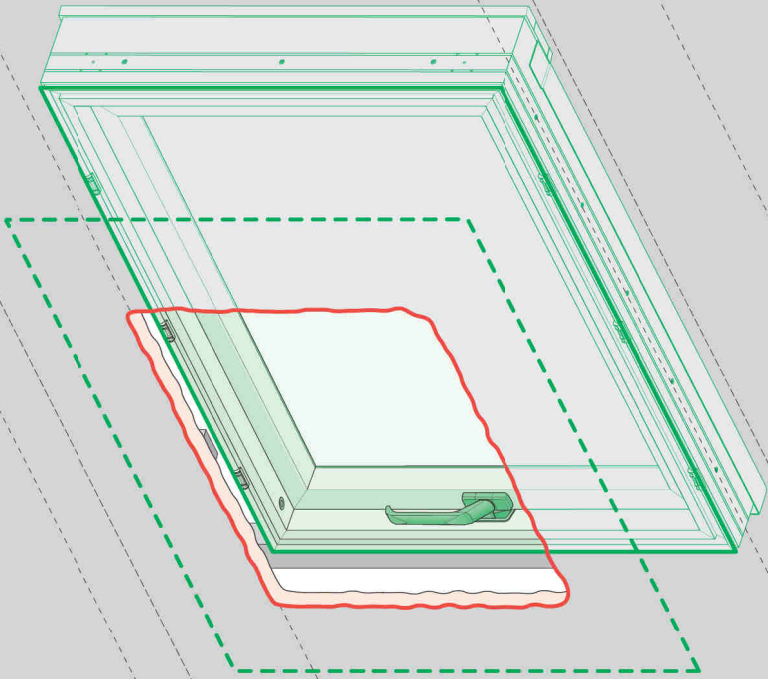

2a

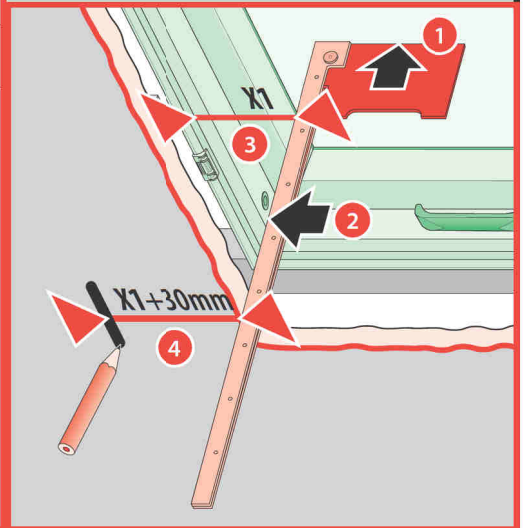
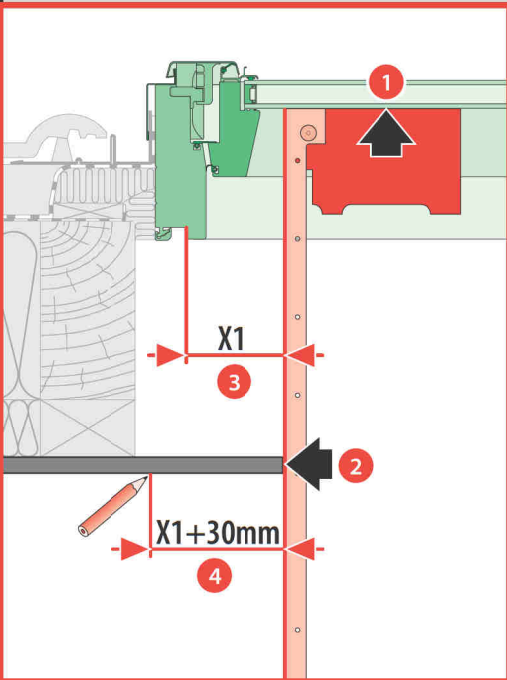
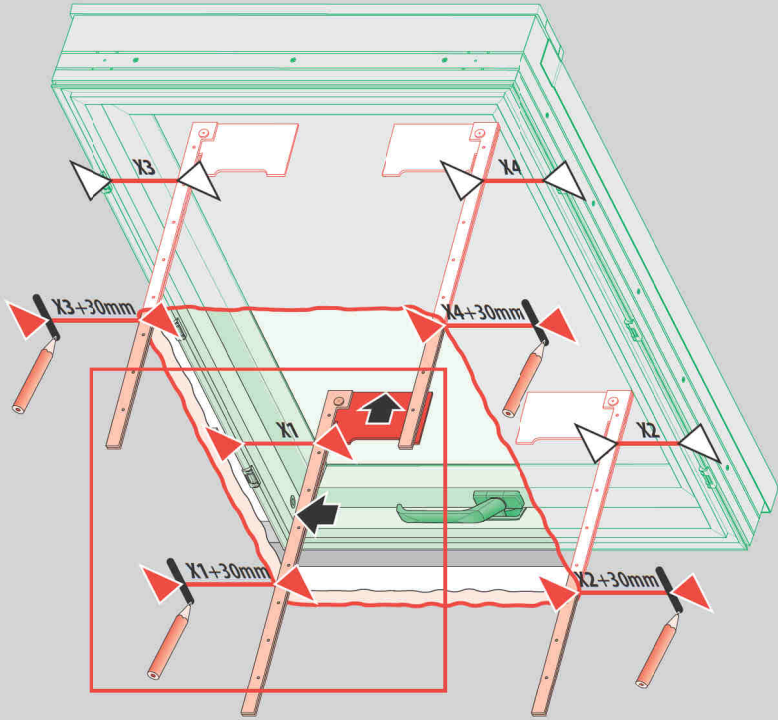

2b

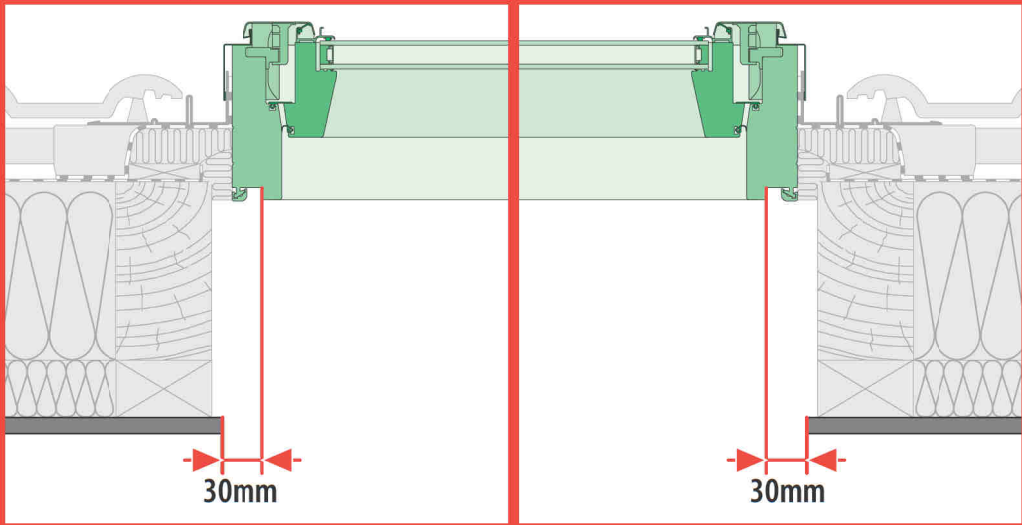
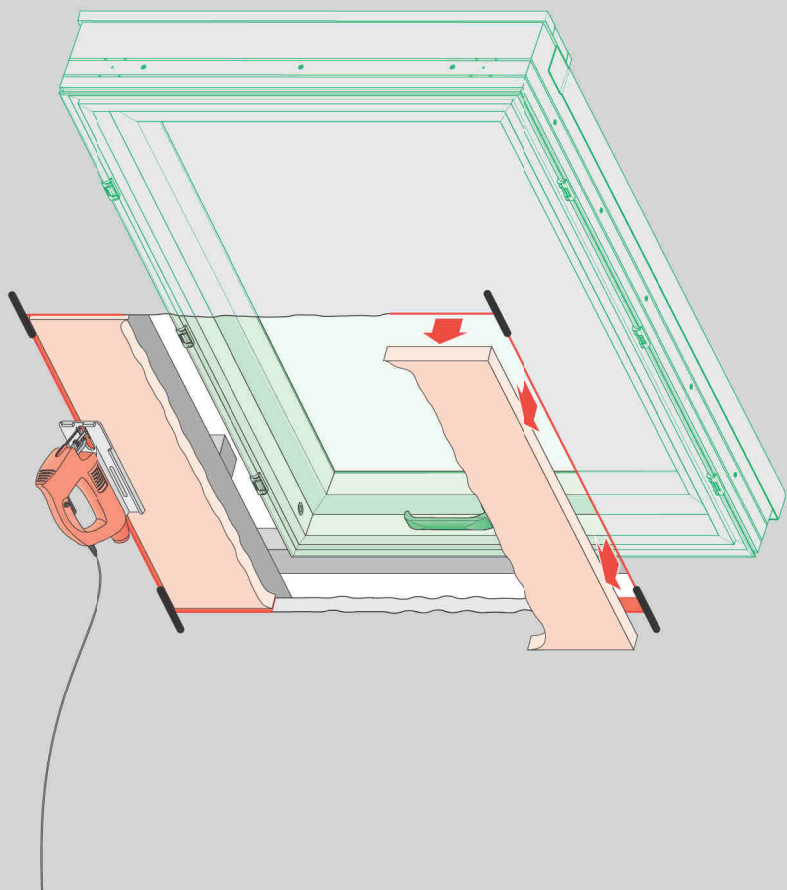

3a

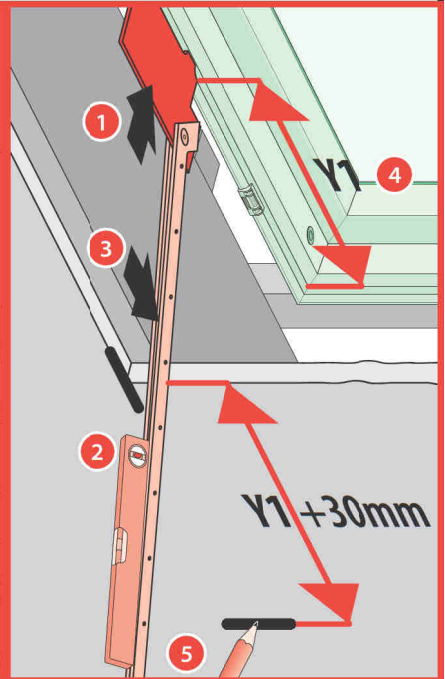
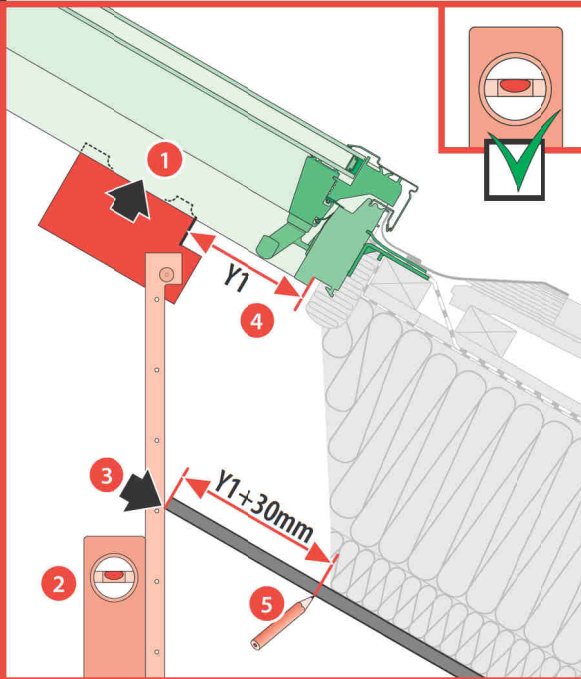
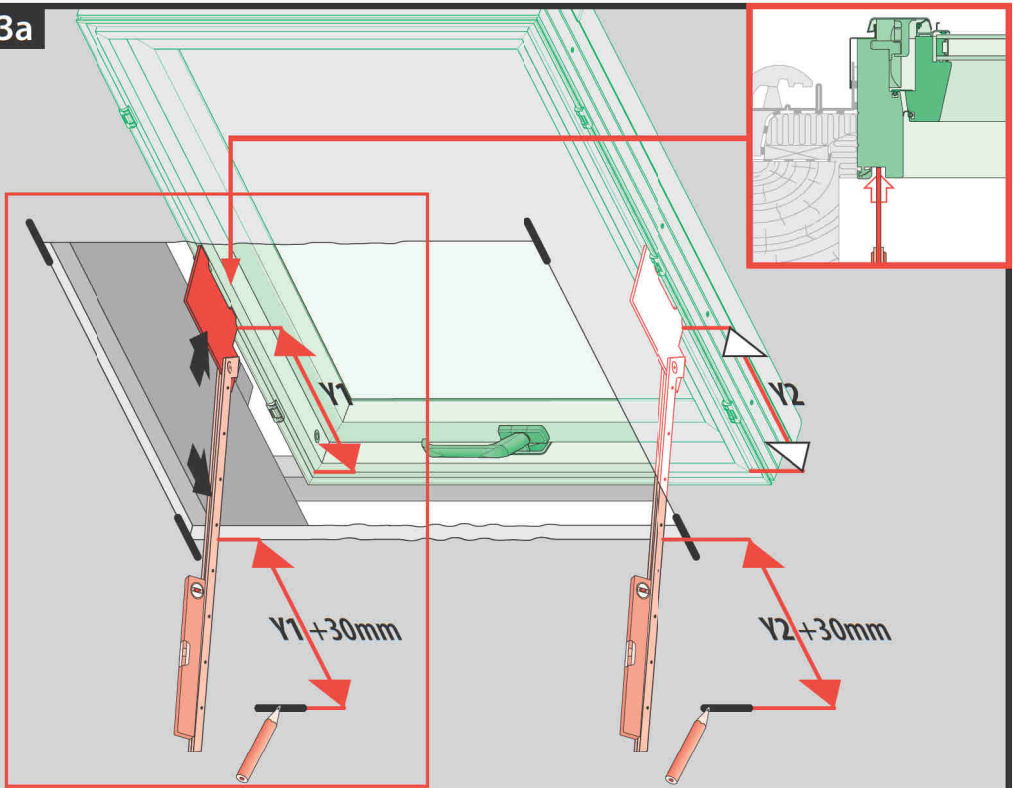

3b

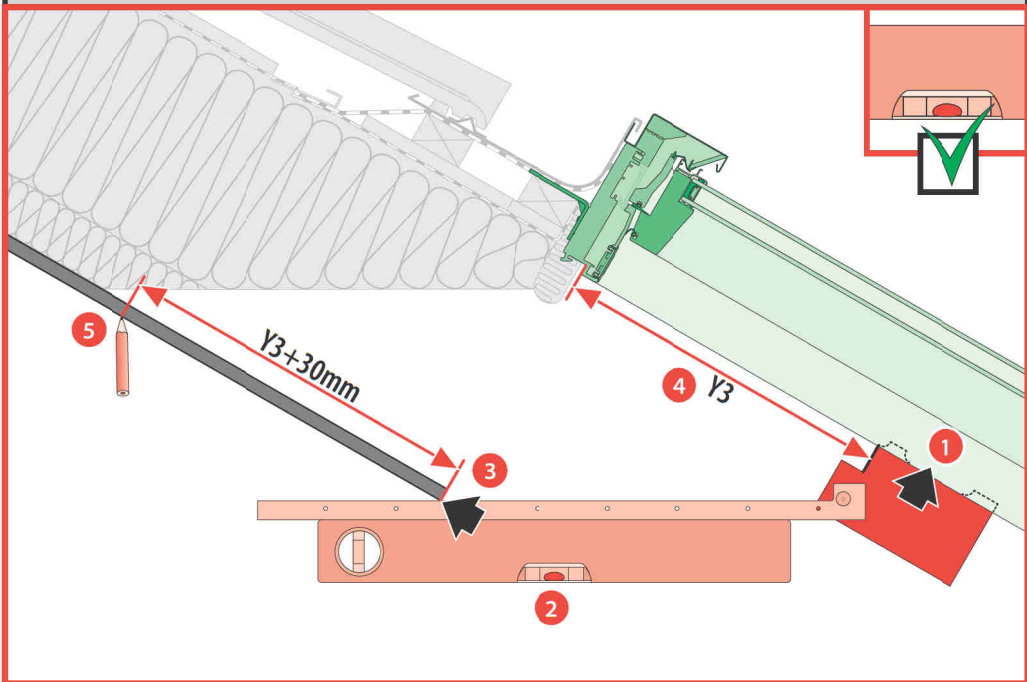
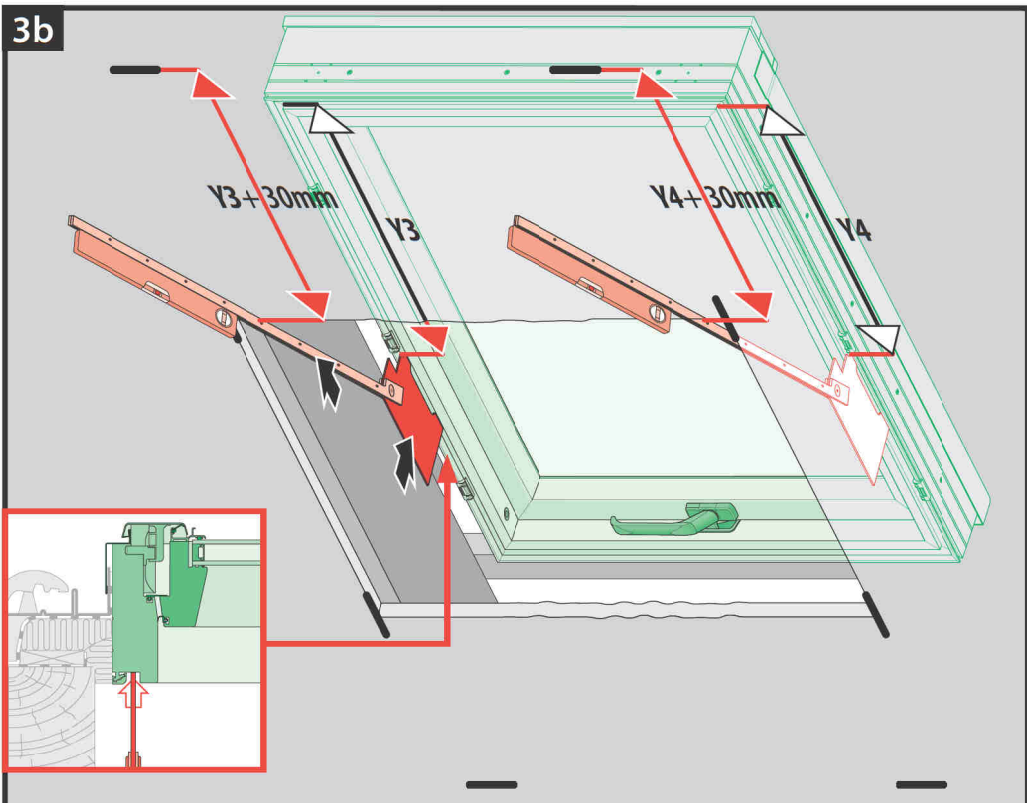

3c

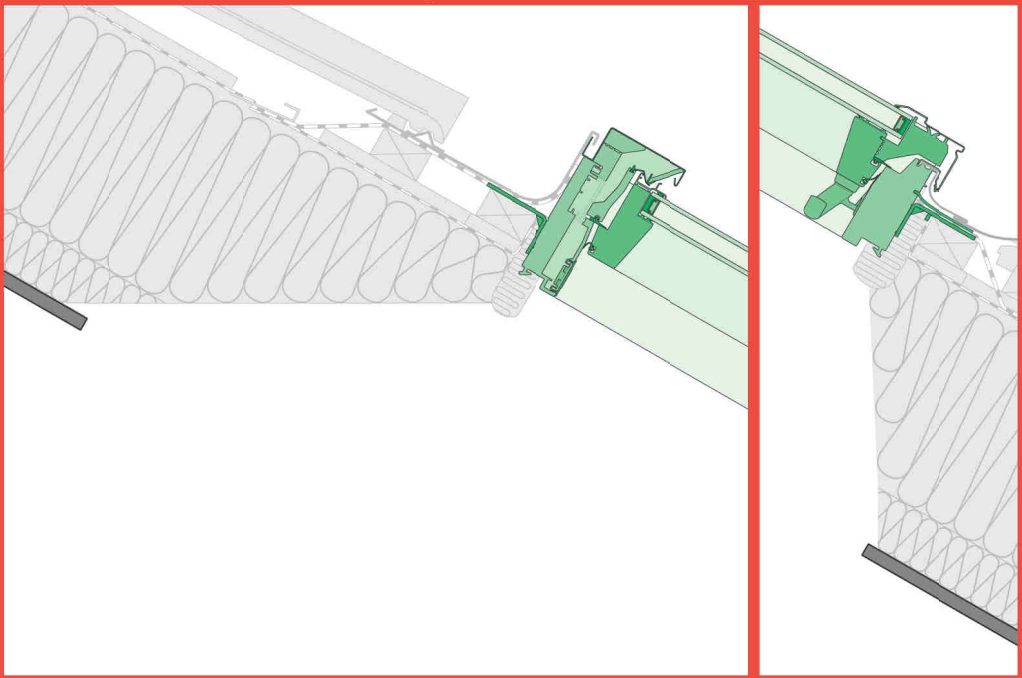
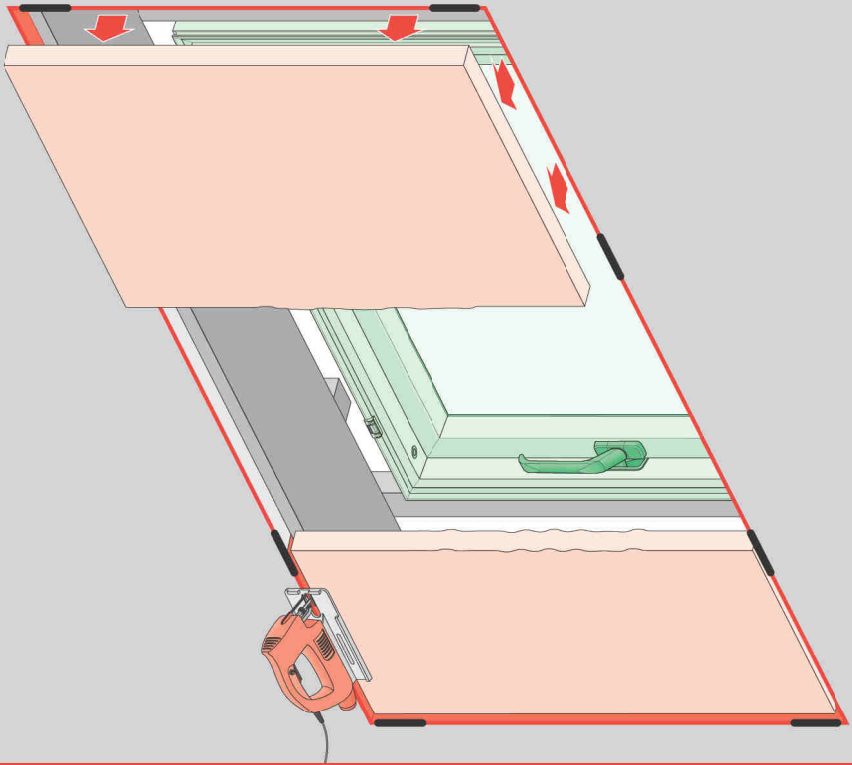

4a

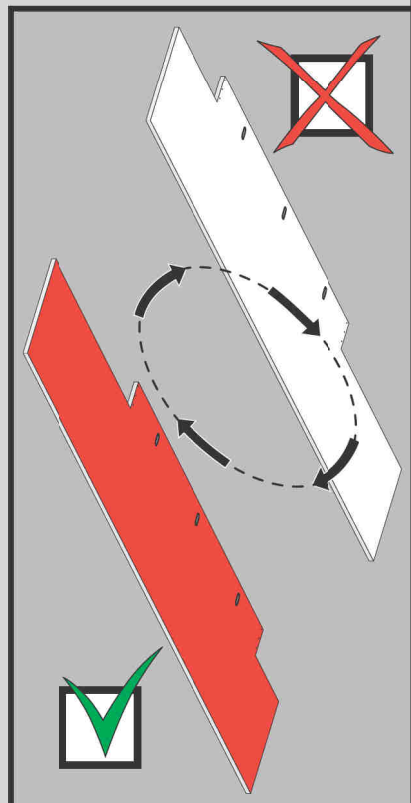
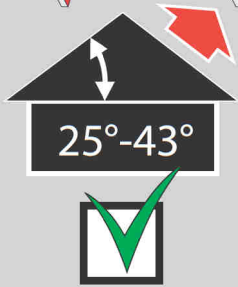
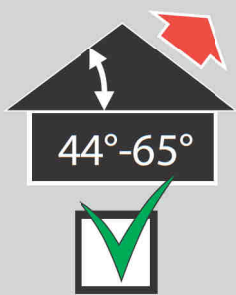
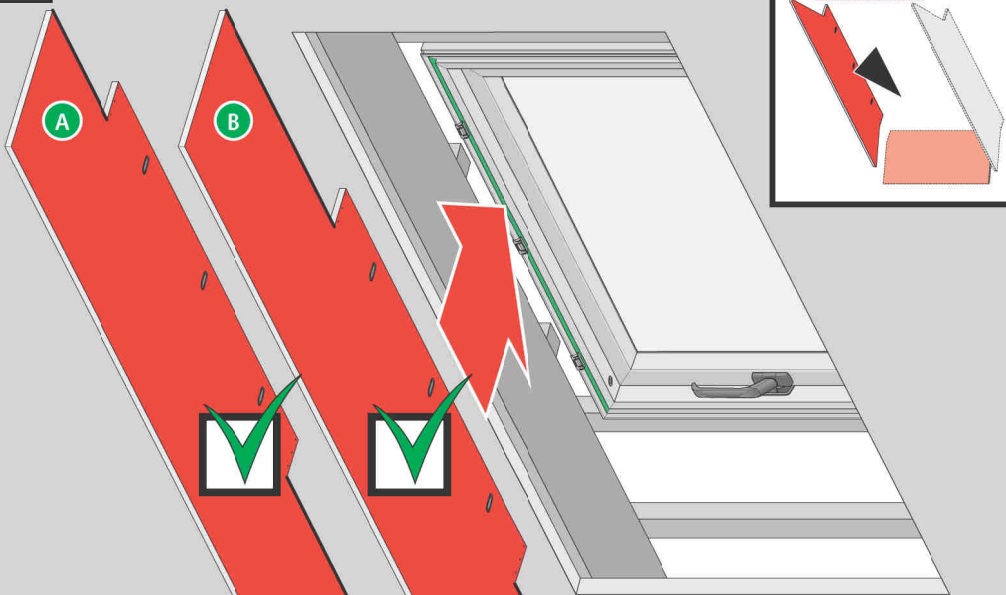

4b

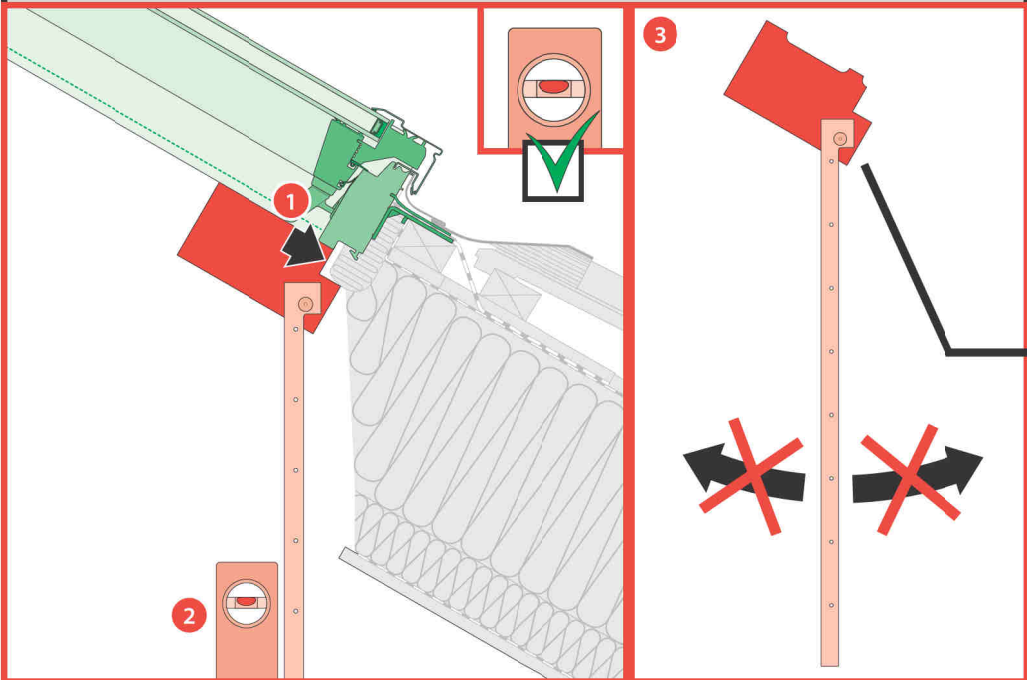
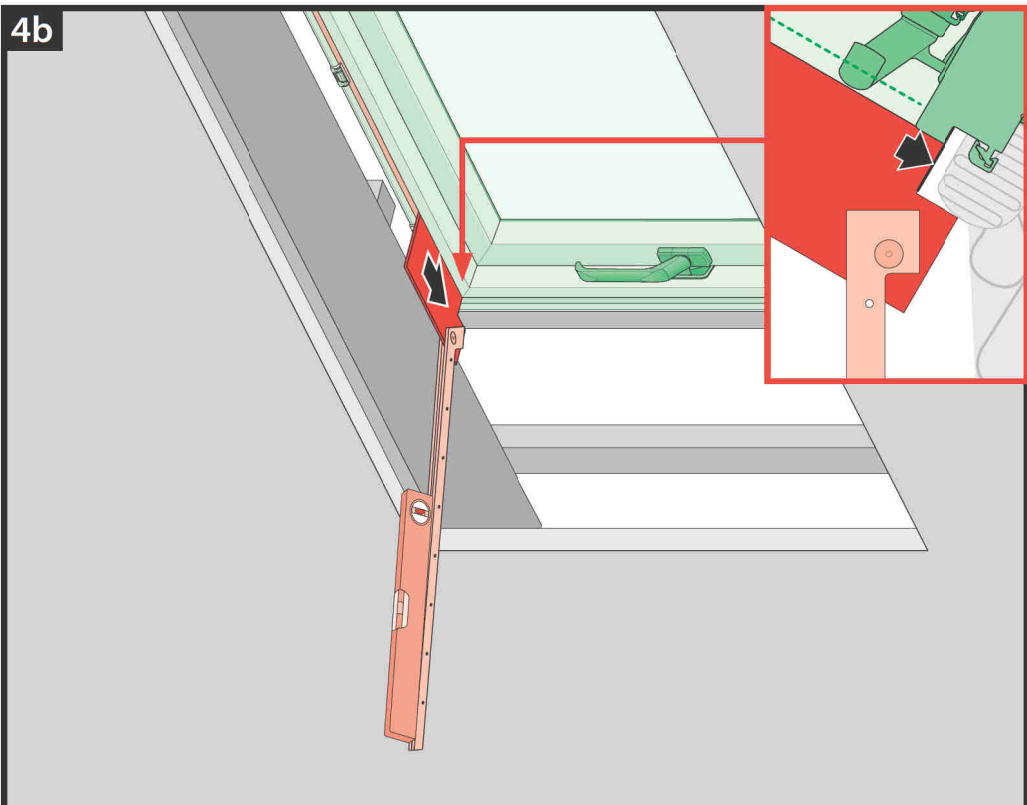

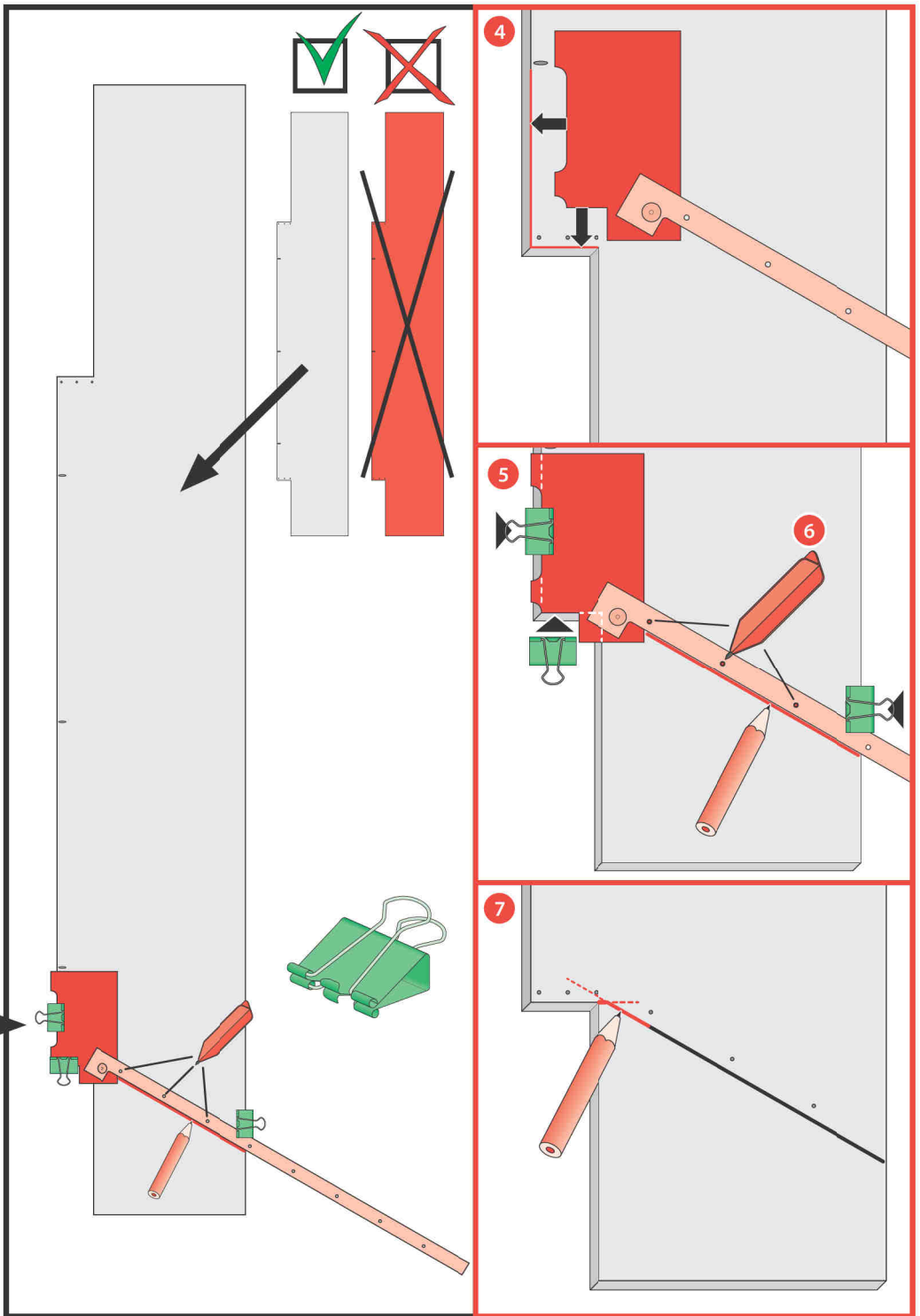

4c

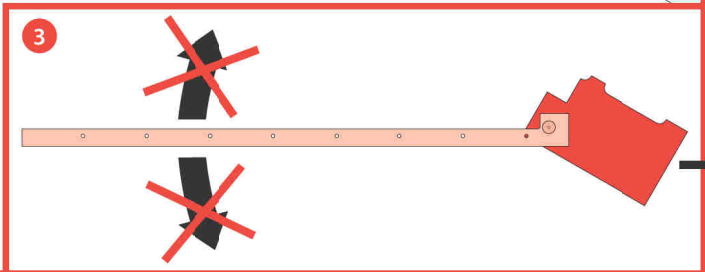
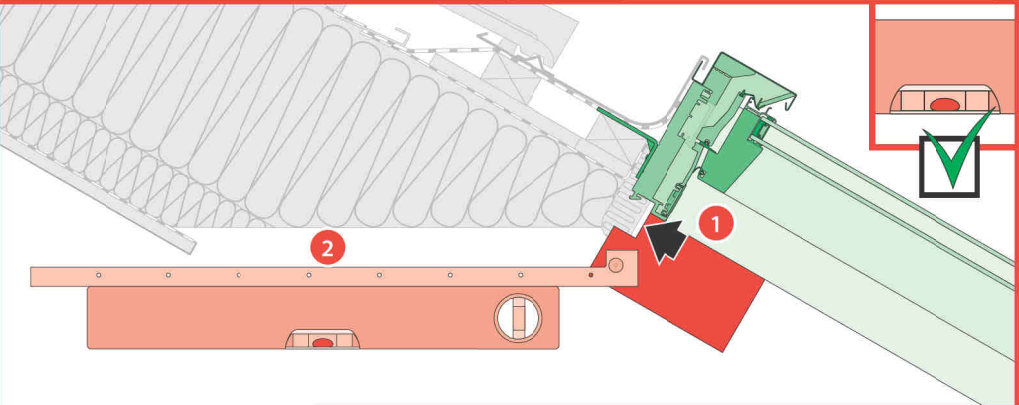
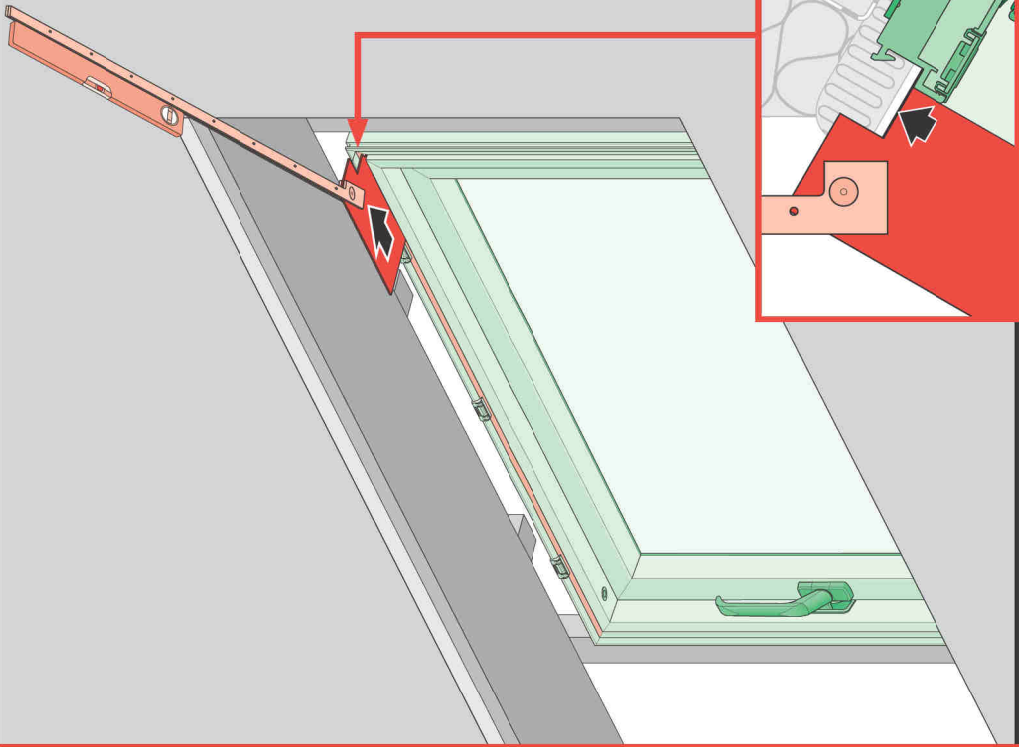

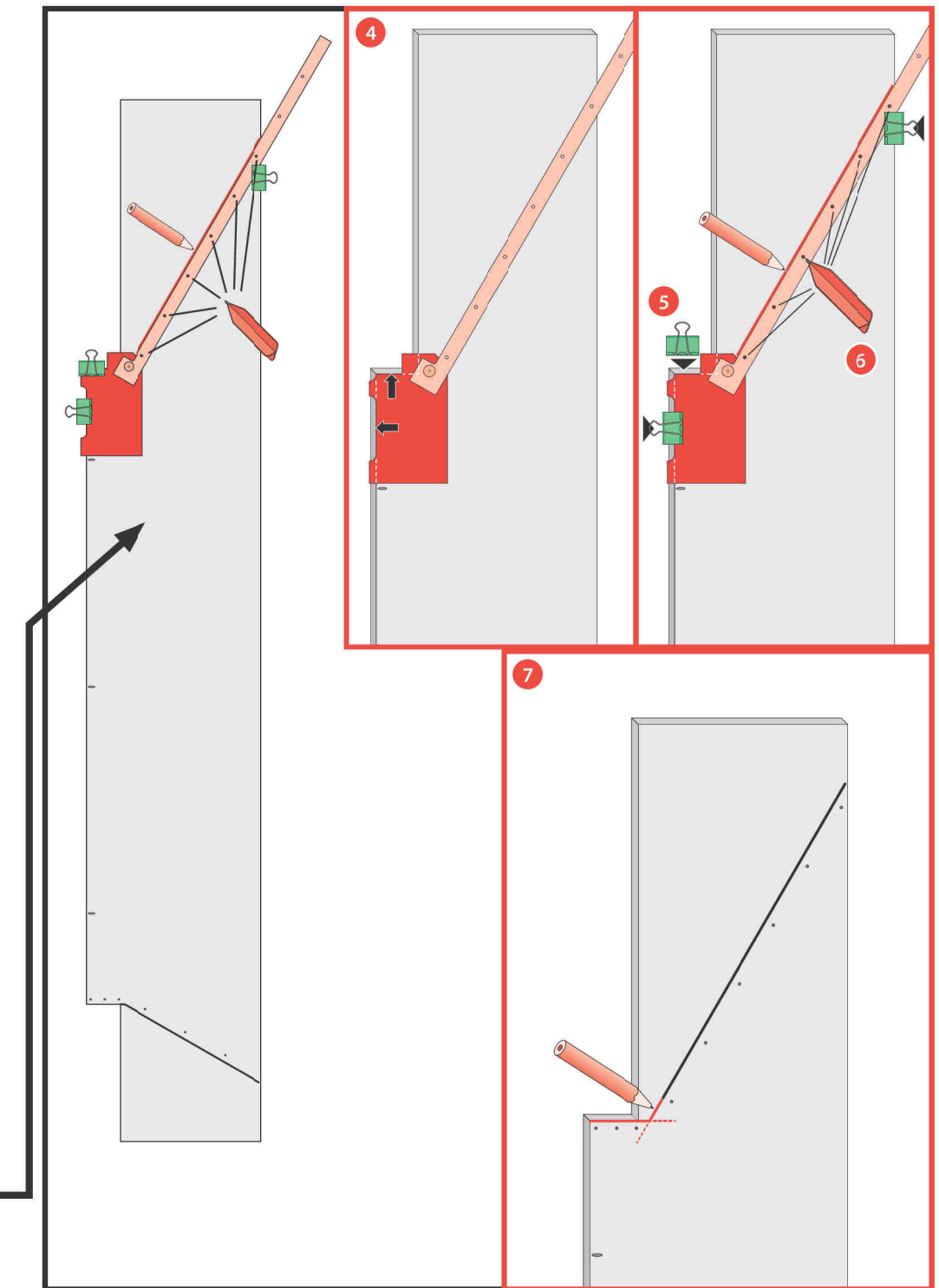

4d

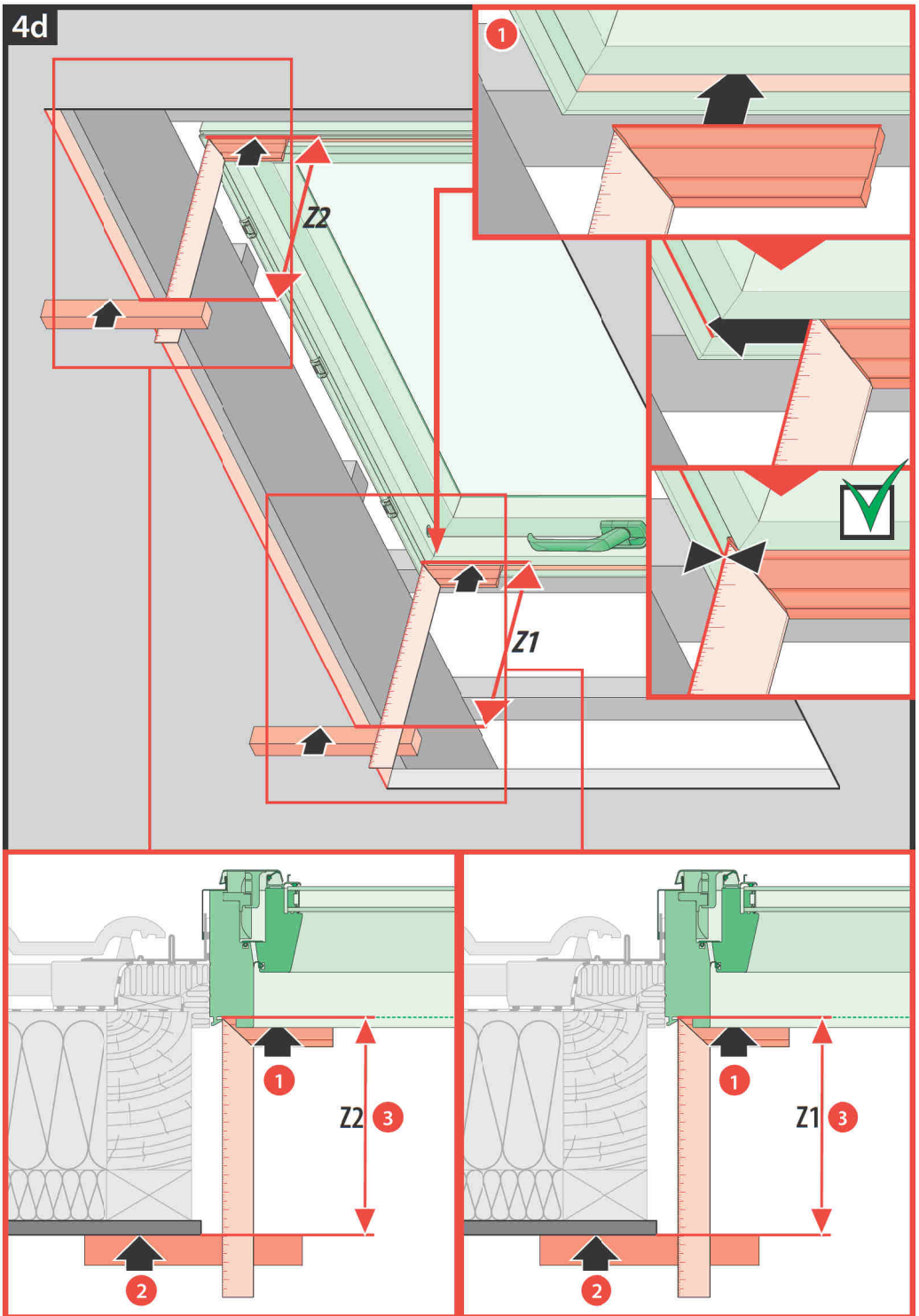

4e 1

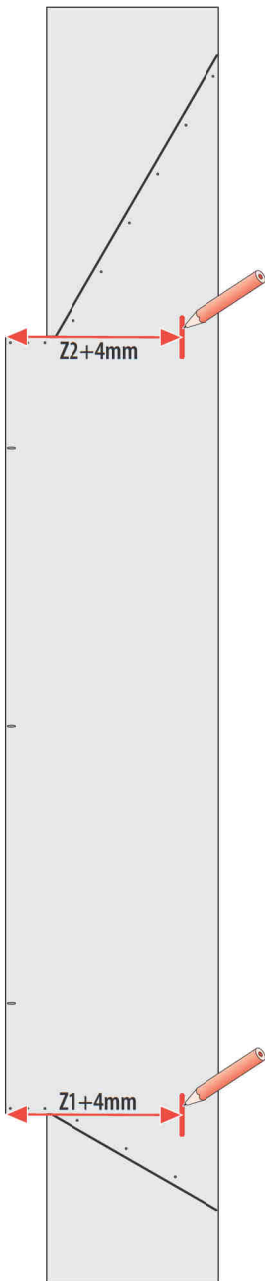

2

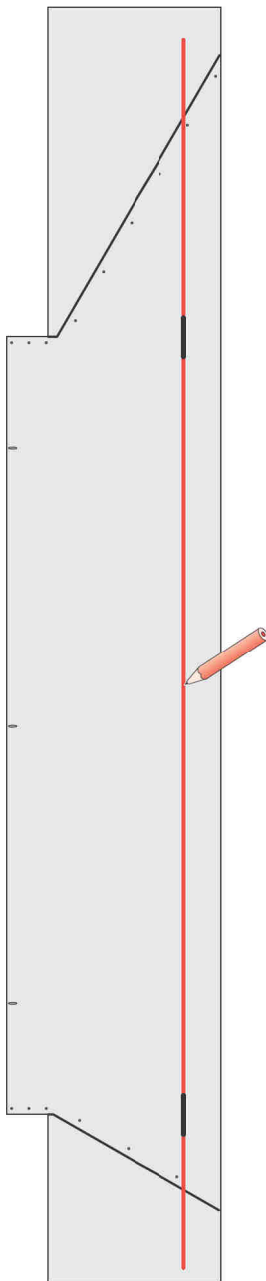

3

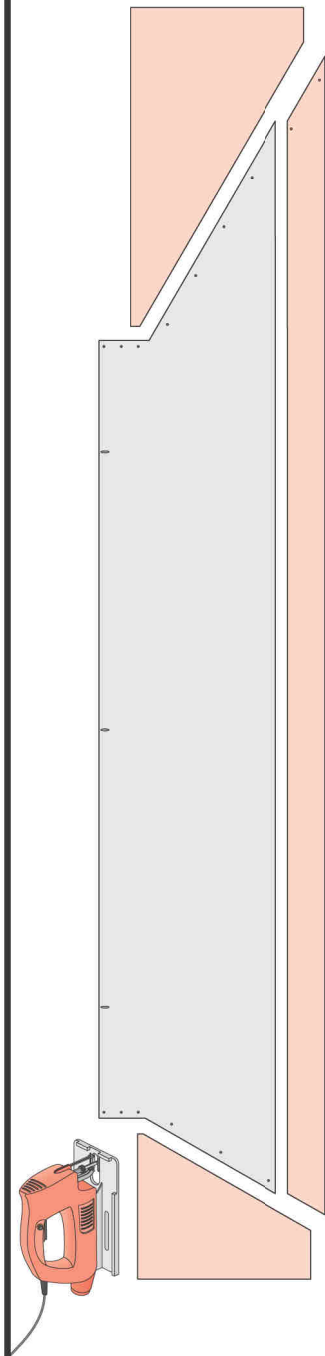

4f

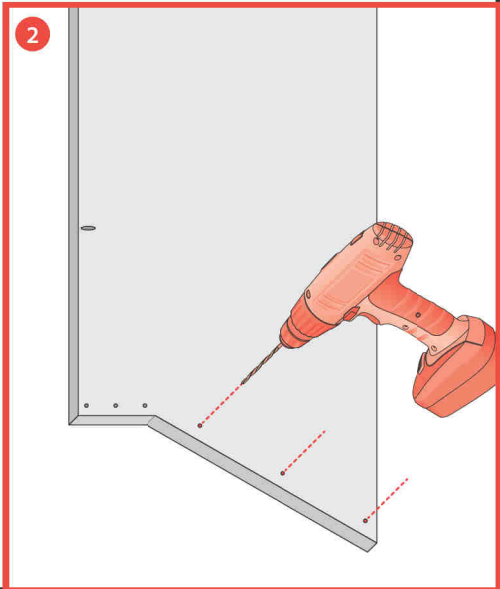
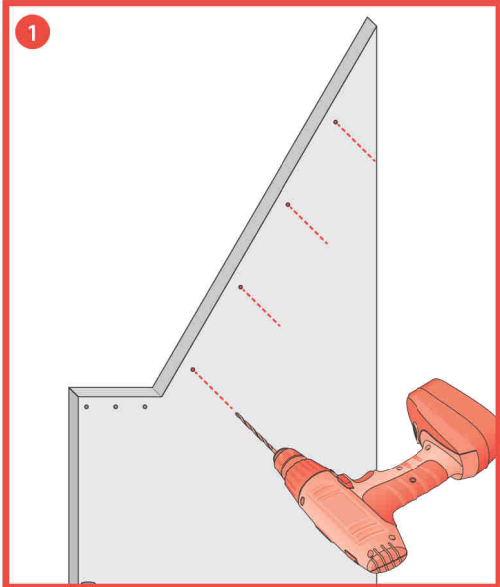
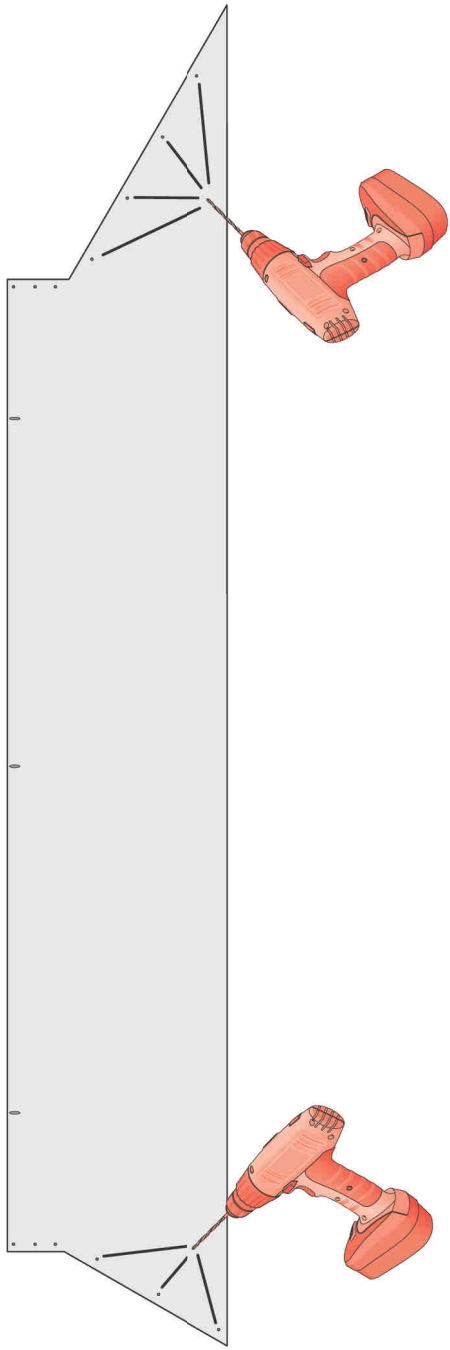
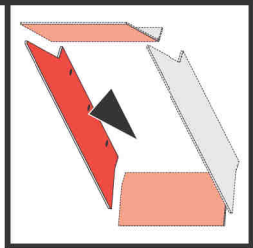

5a

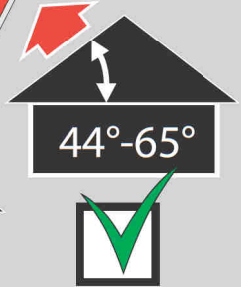
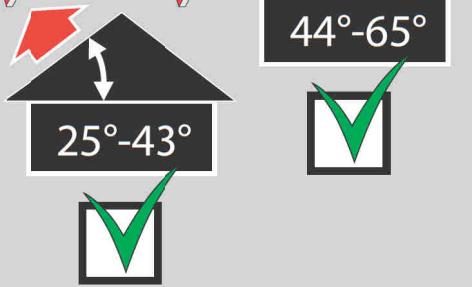
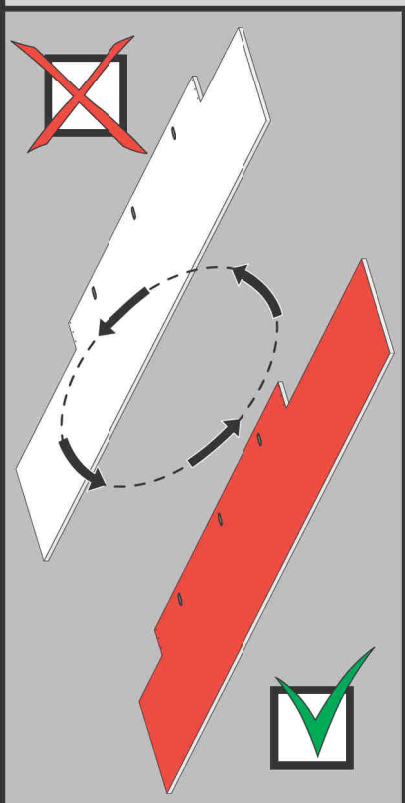
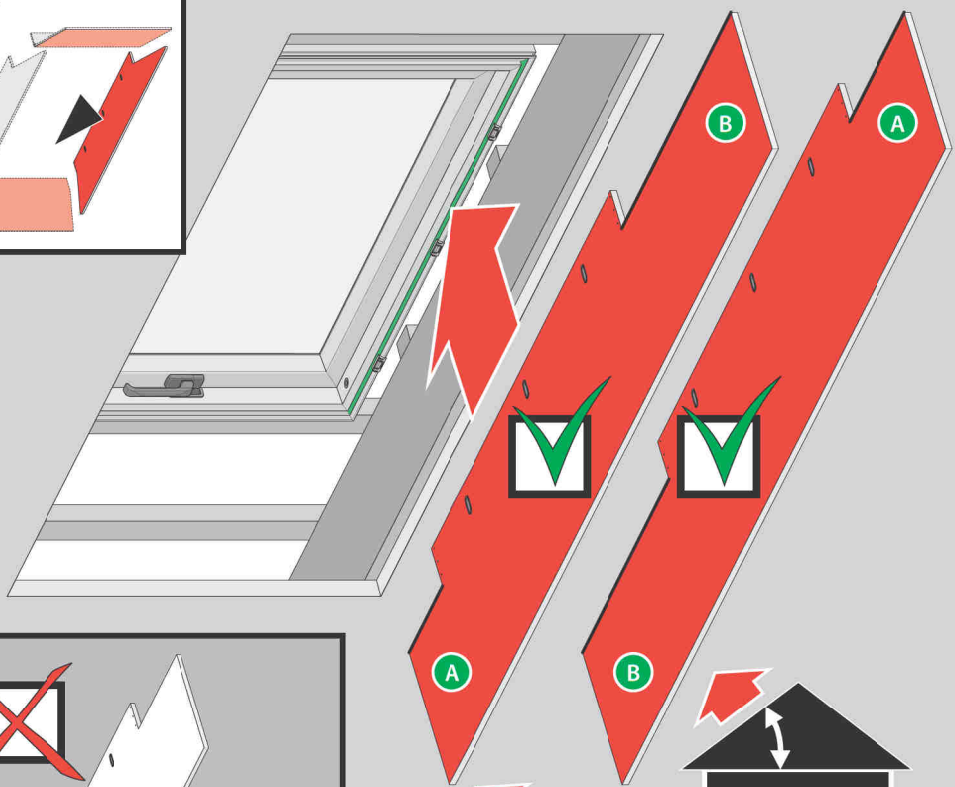
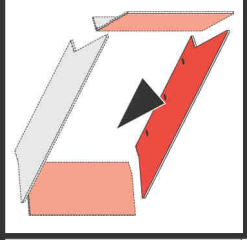

5b

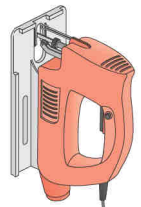
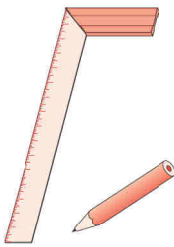
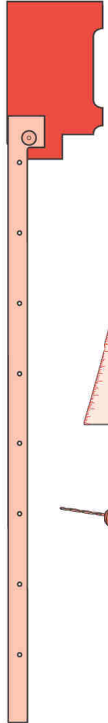
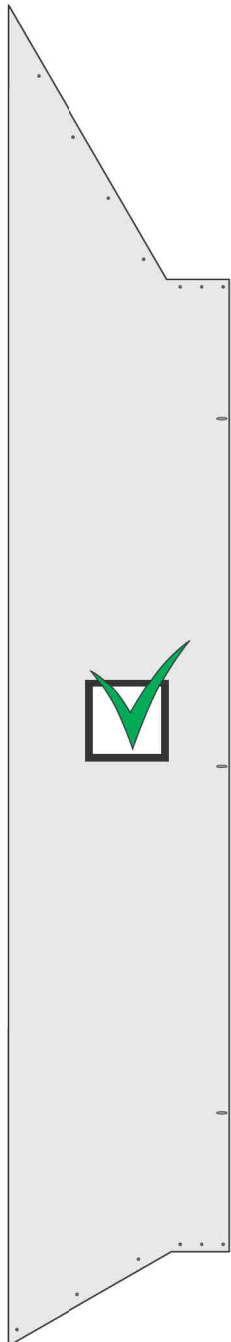
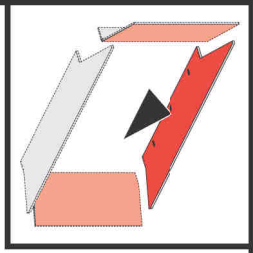

- 4b
- 4c
- 4d
- 4e
- 4f

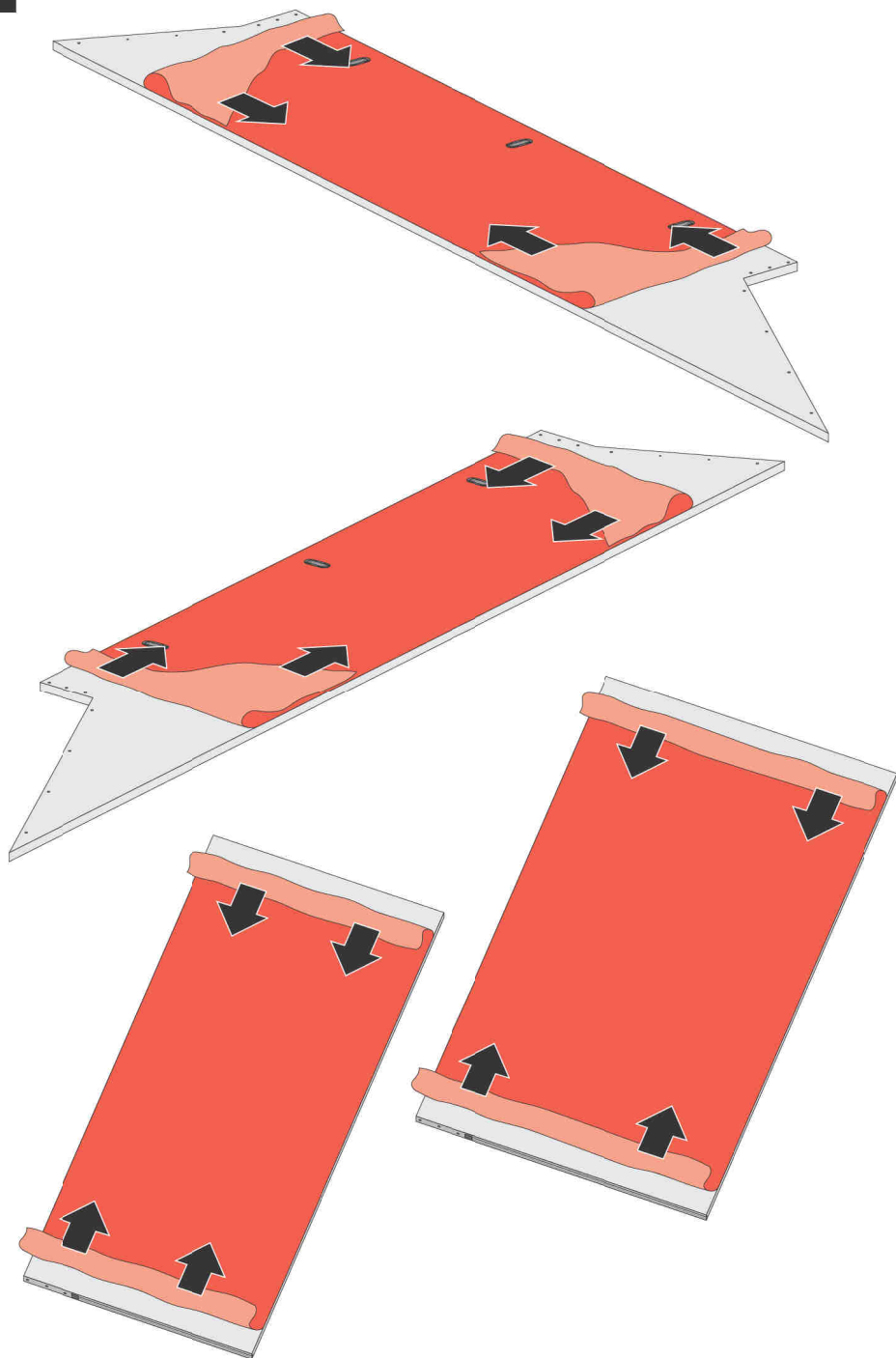

7a

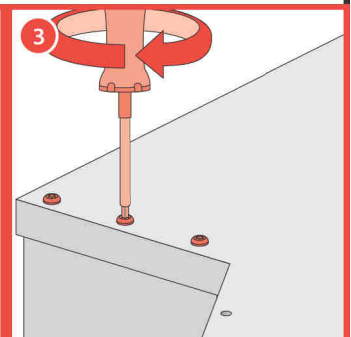
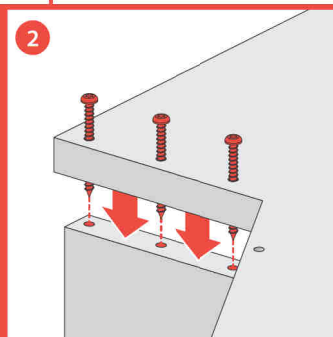
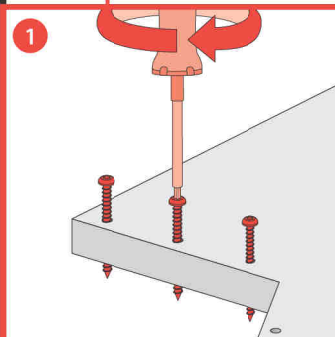
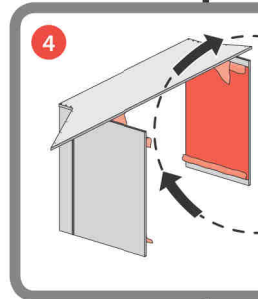
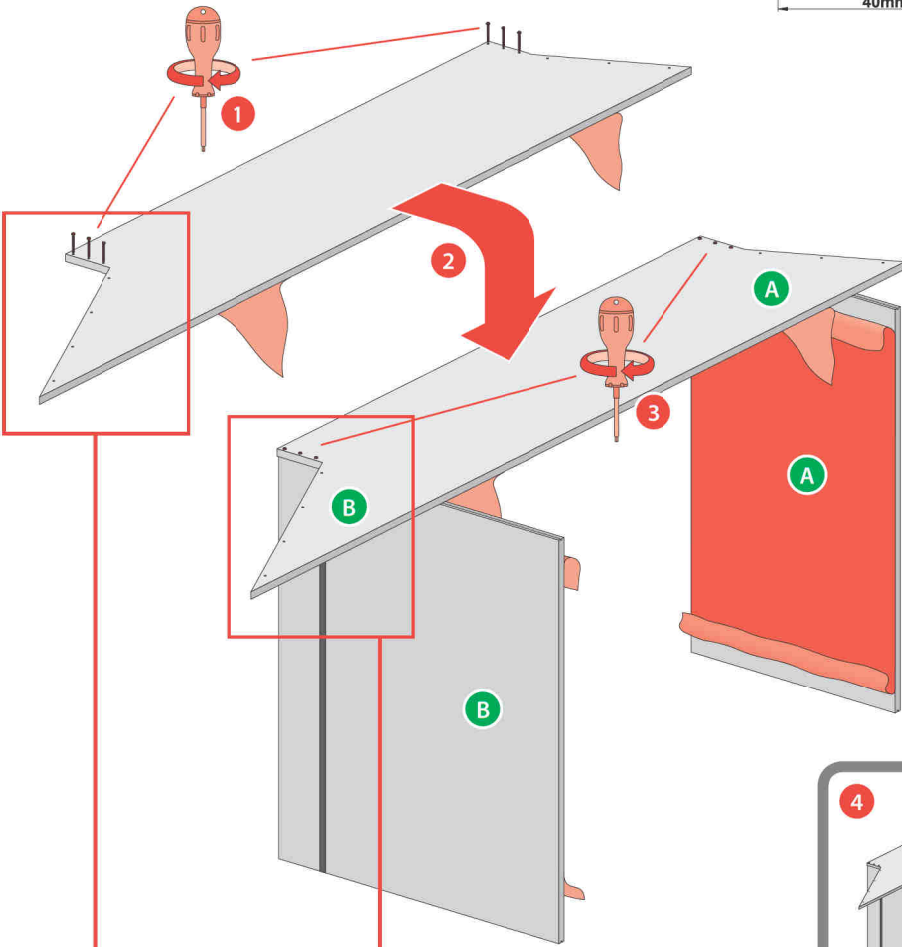

7b

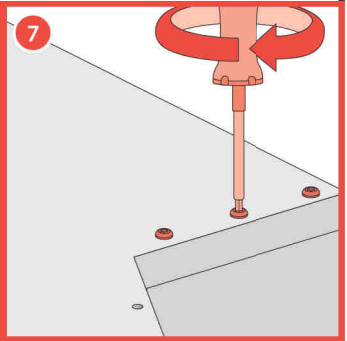
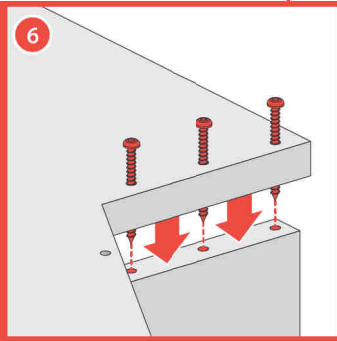
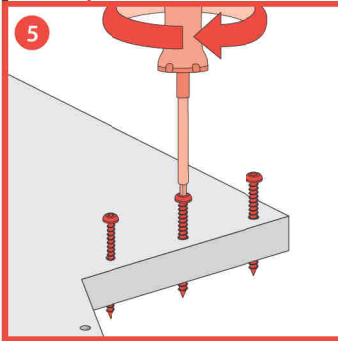
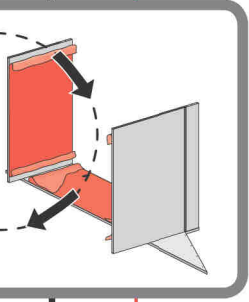
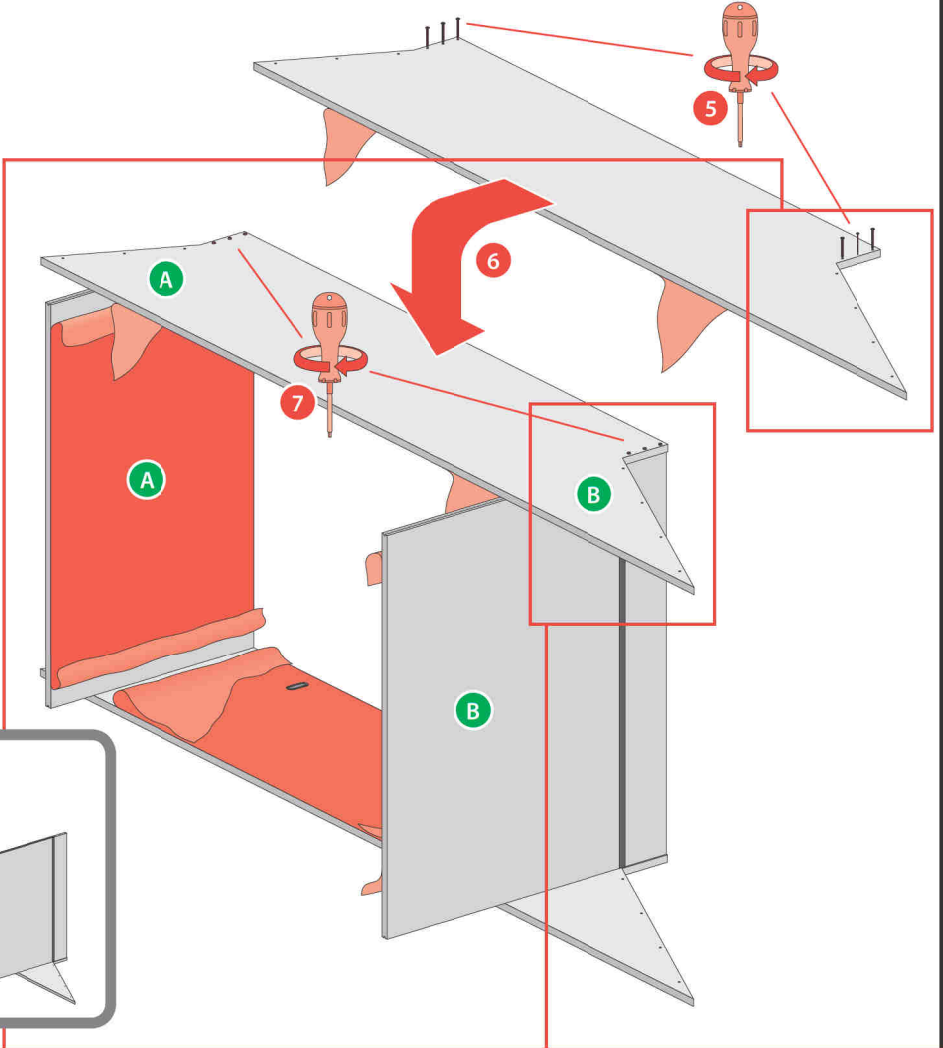

8a

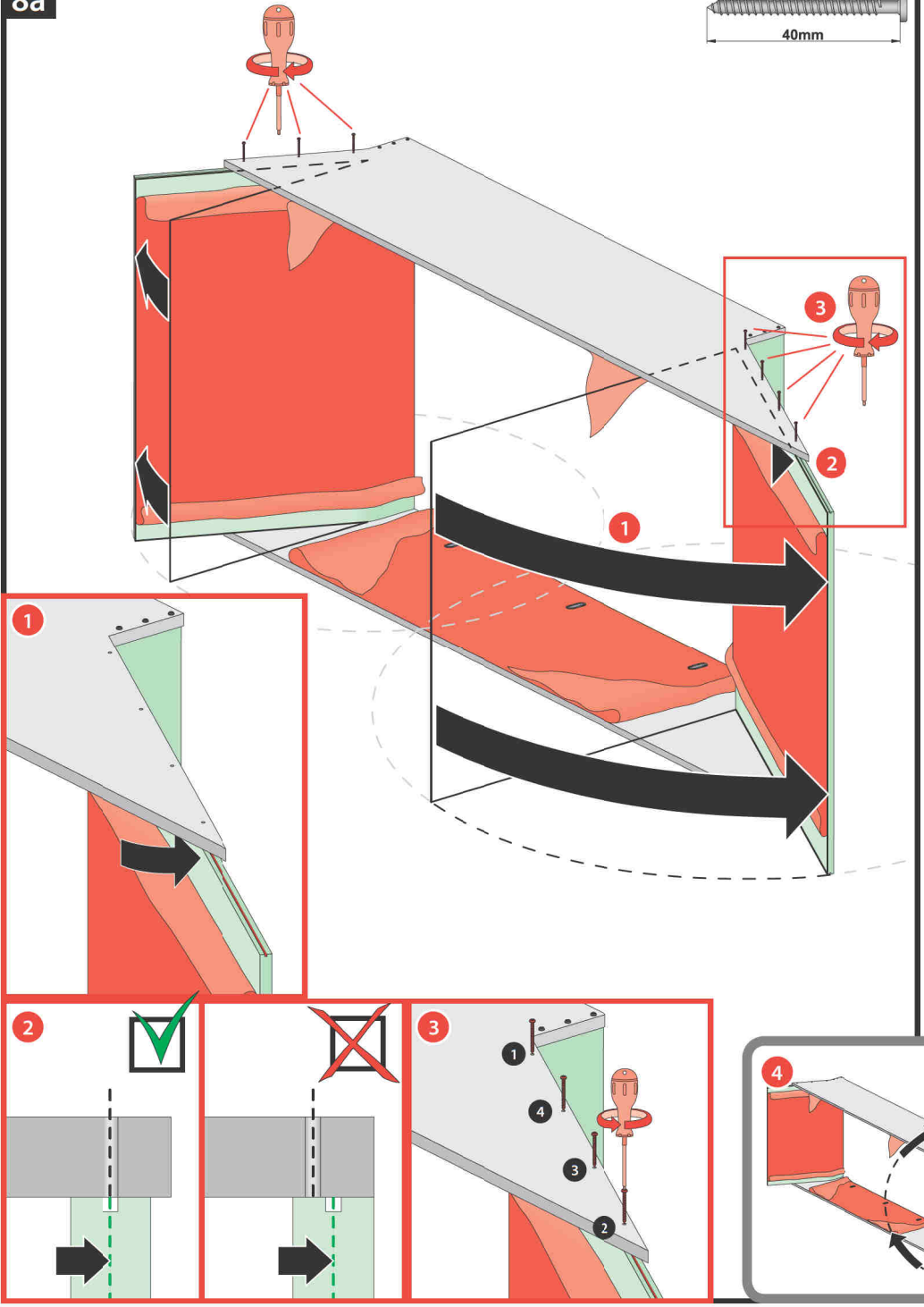

8b

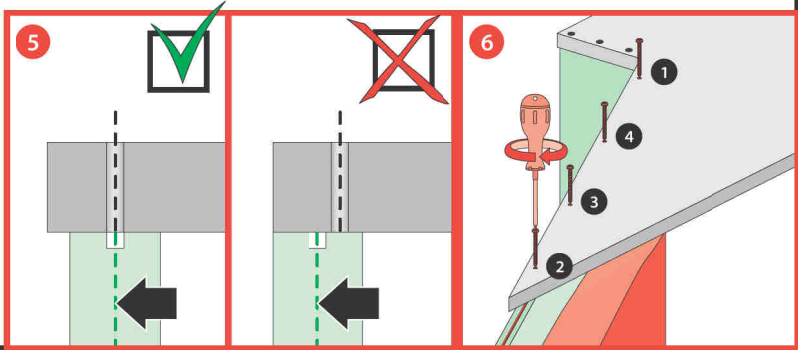
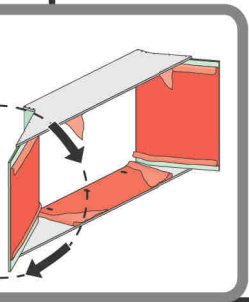
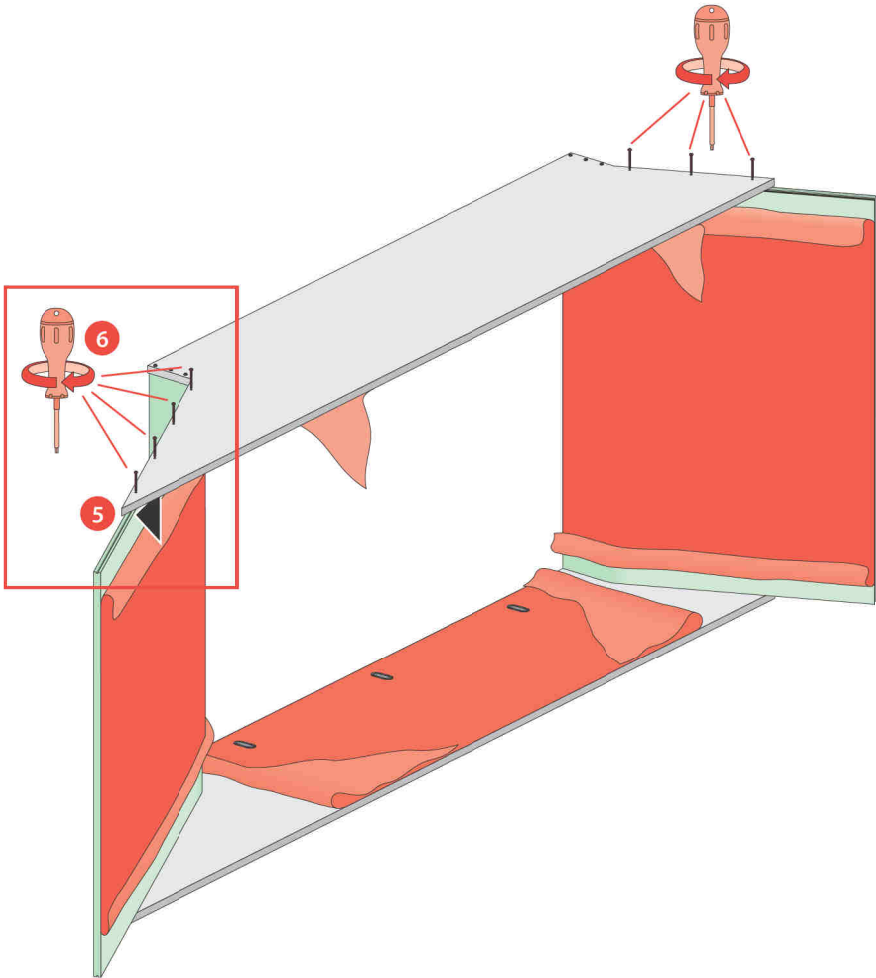

9a

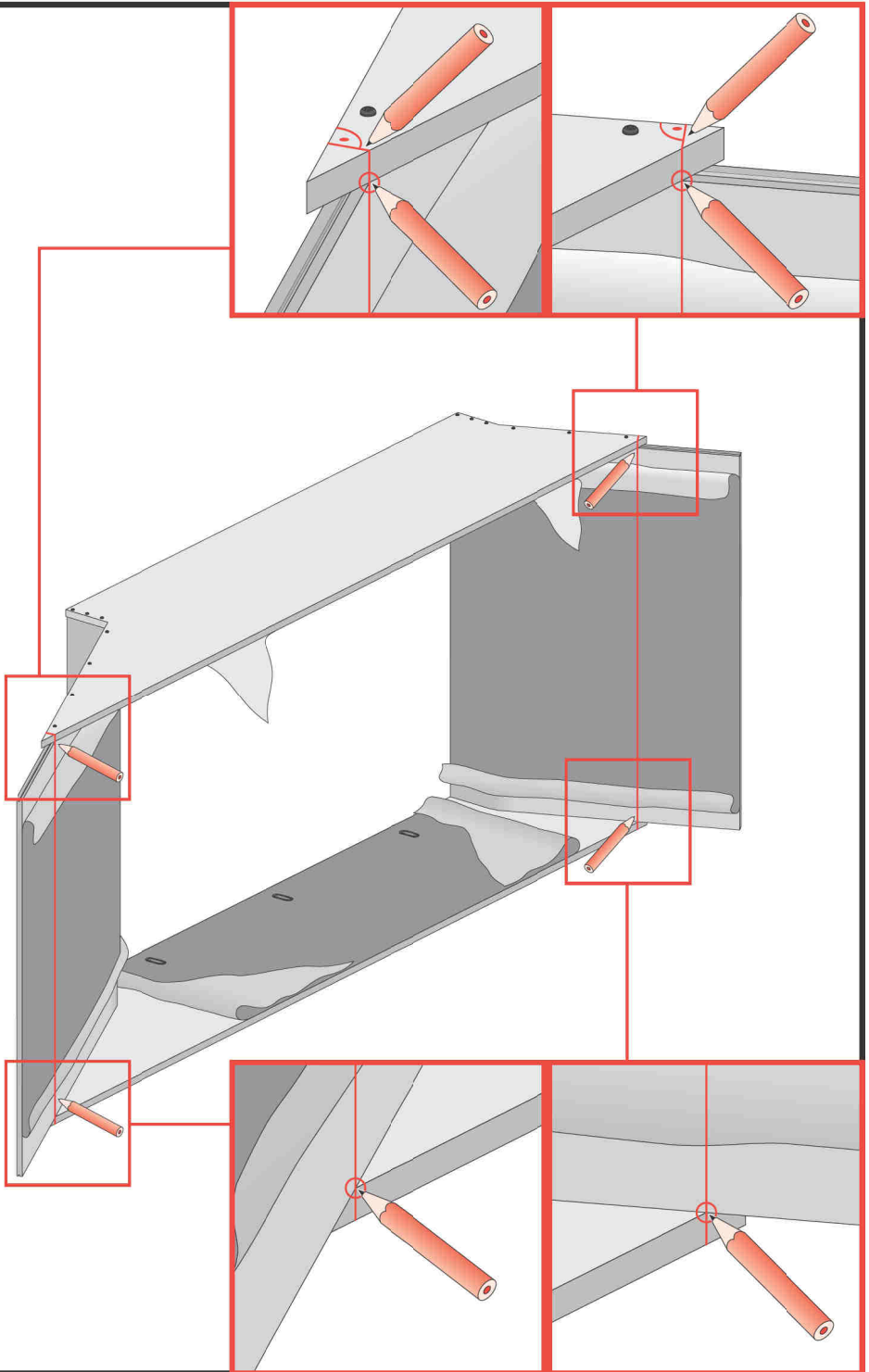

9b

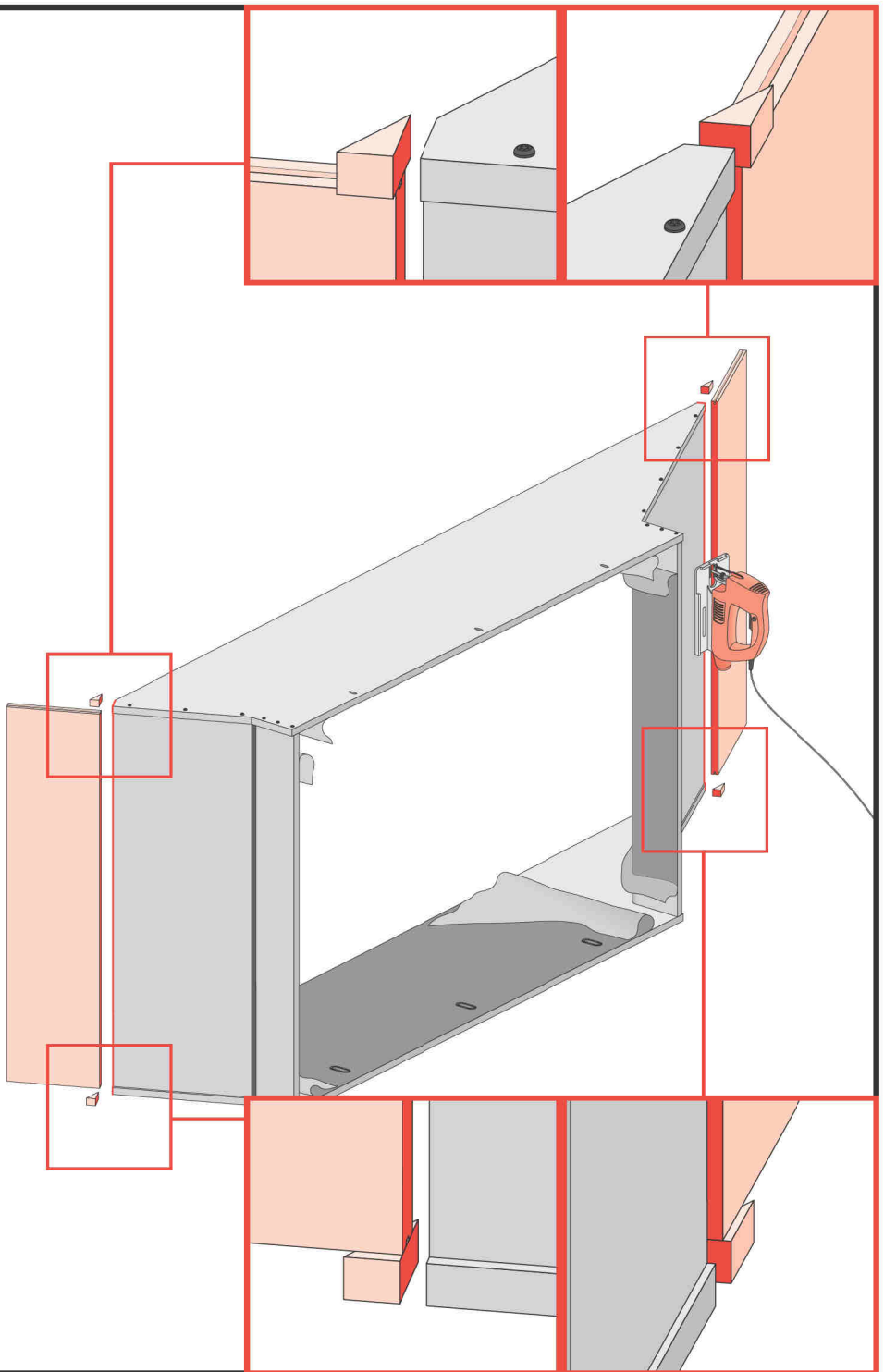

10a

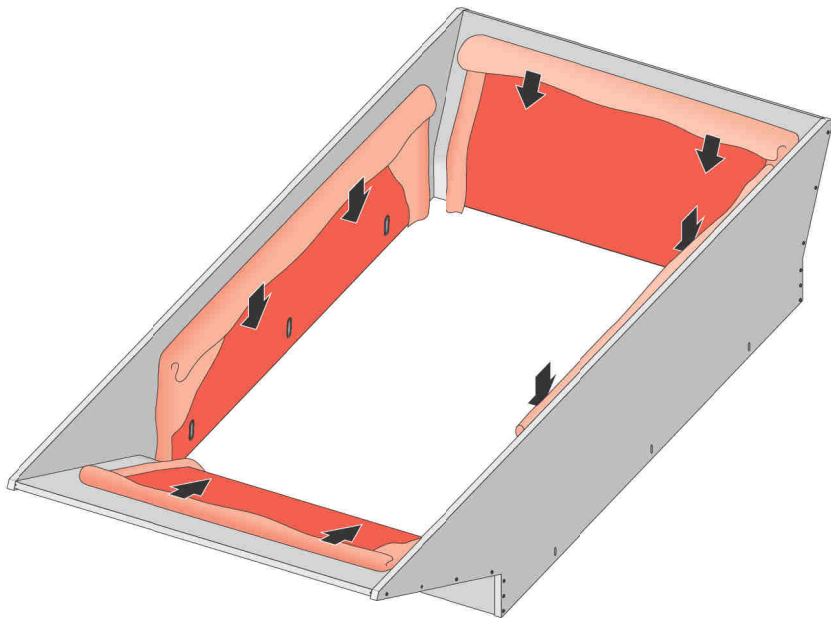

10b

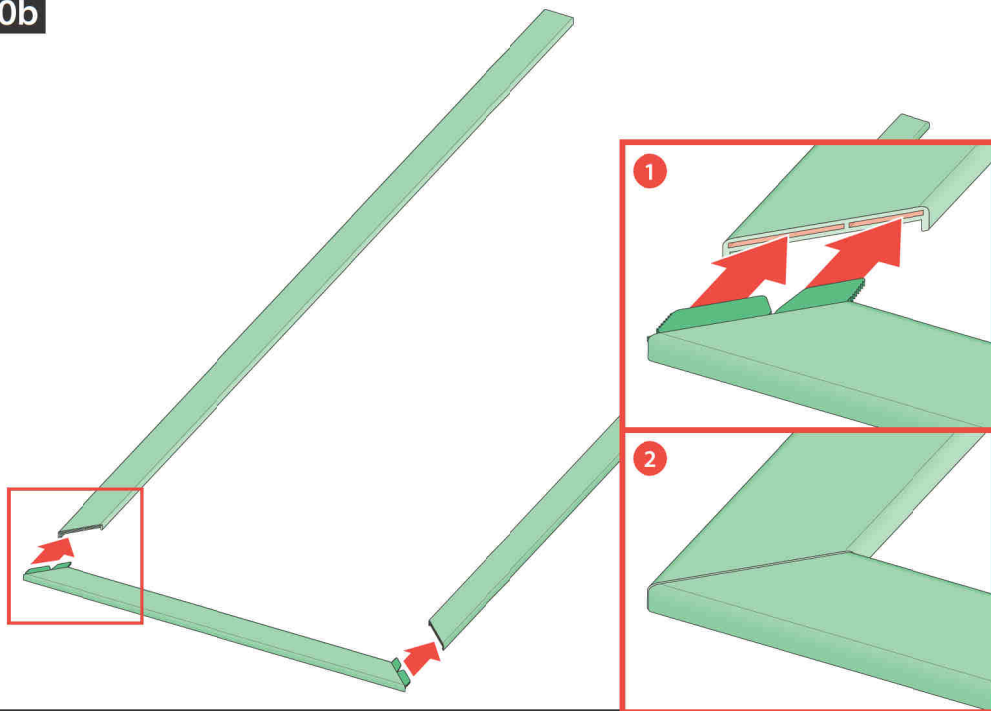

10c

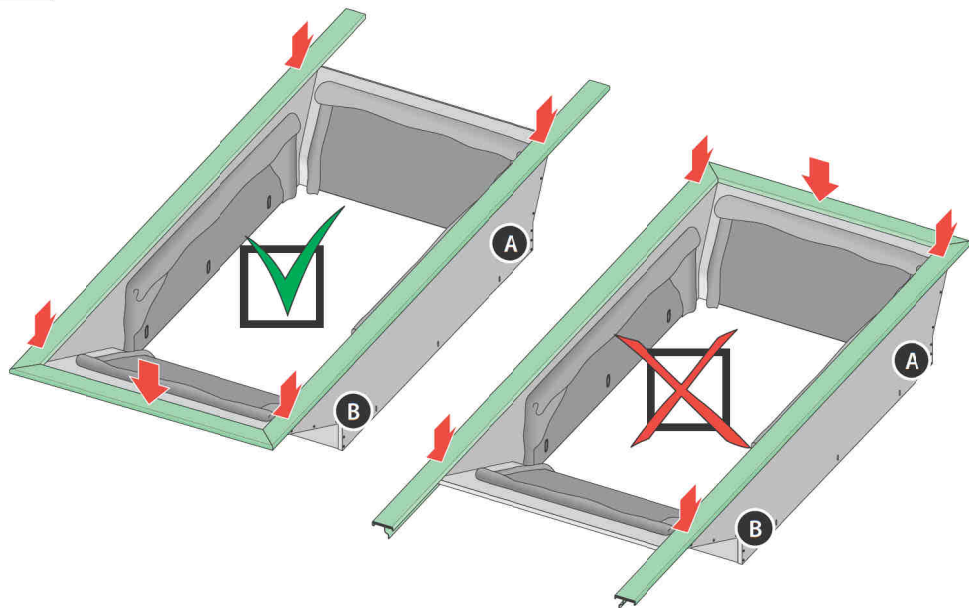

10d

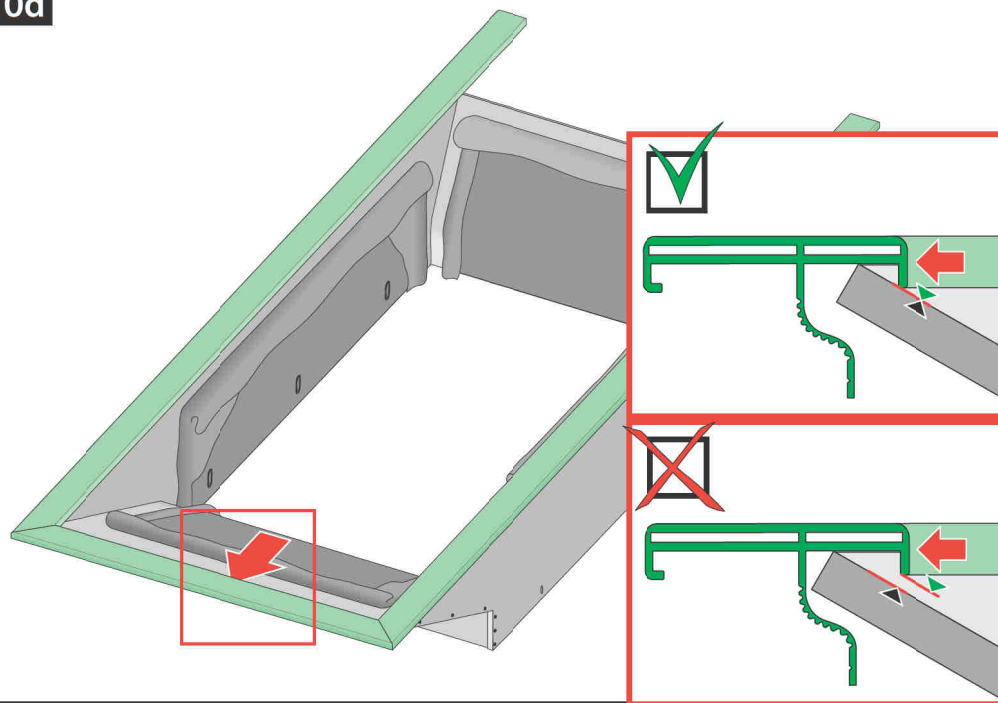

10e

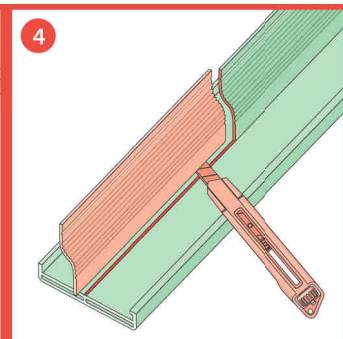
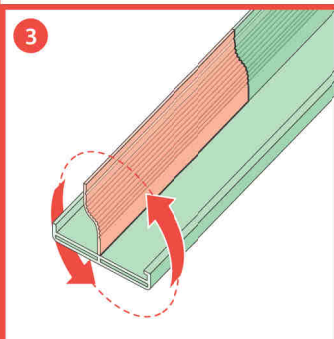
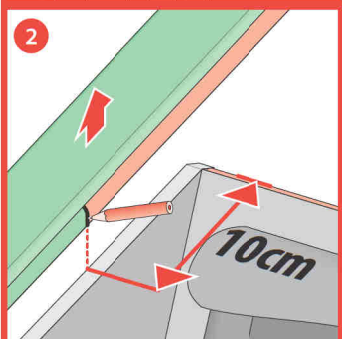
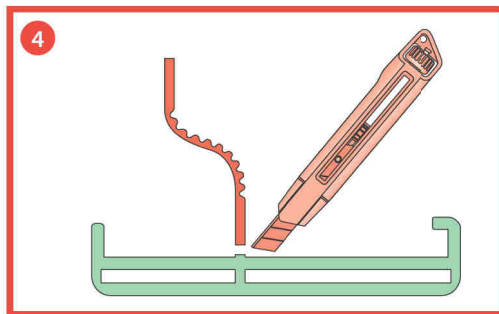
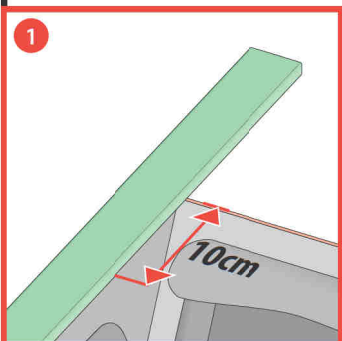
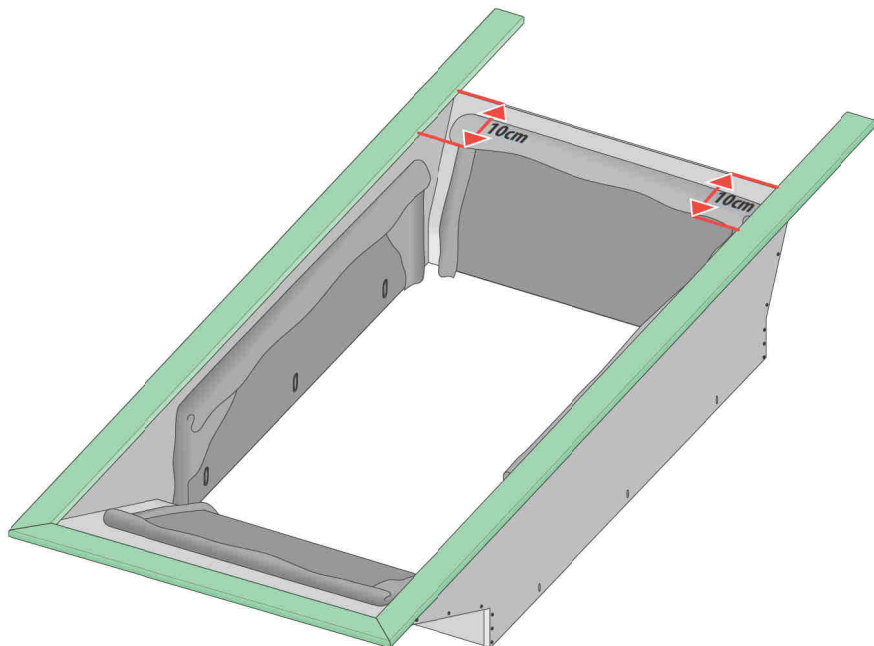

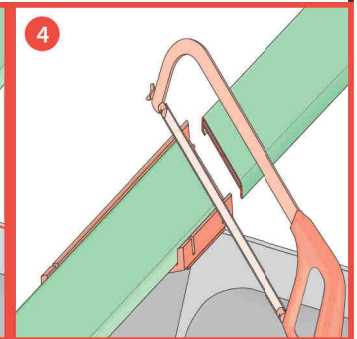
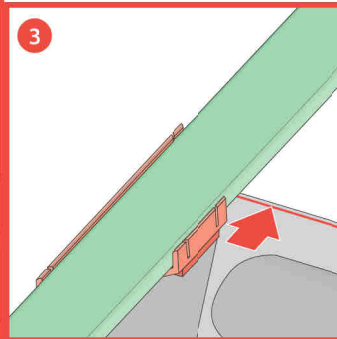
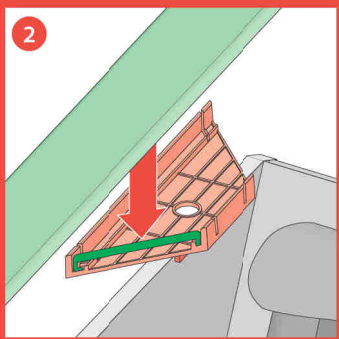
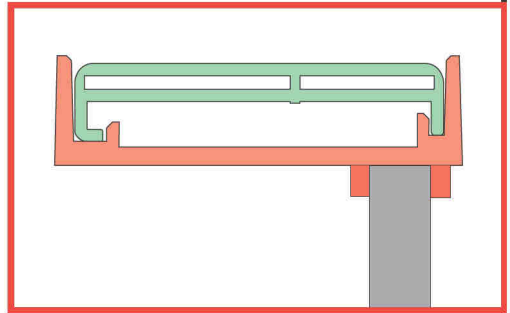
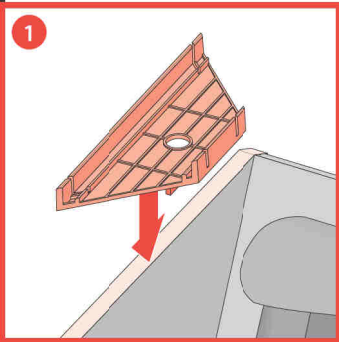
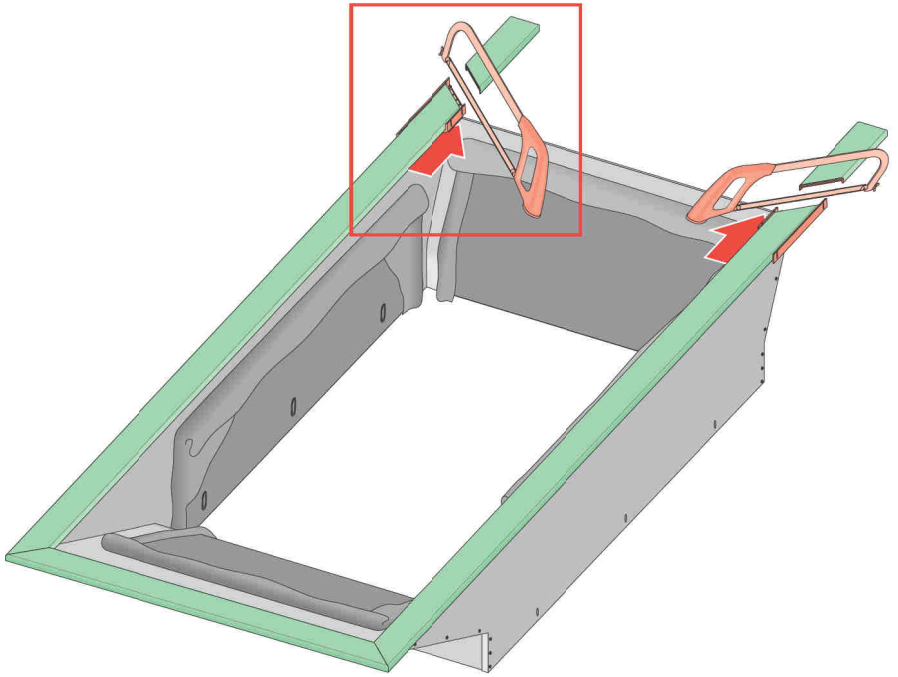

10g

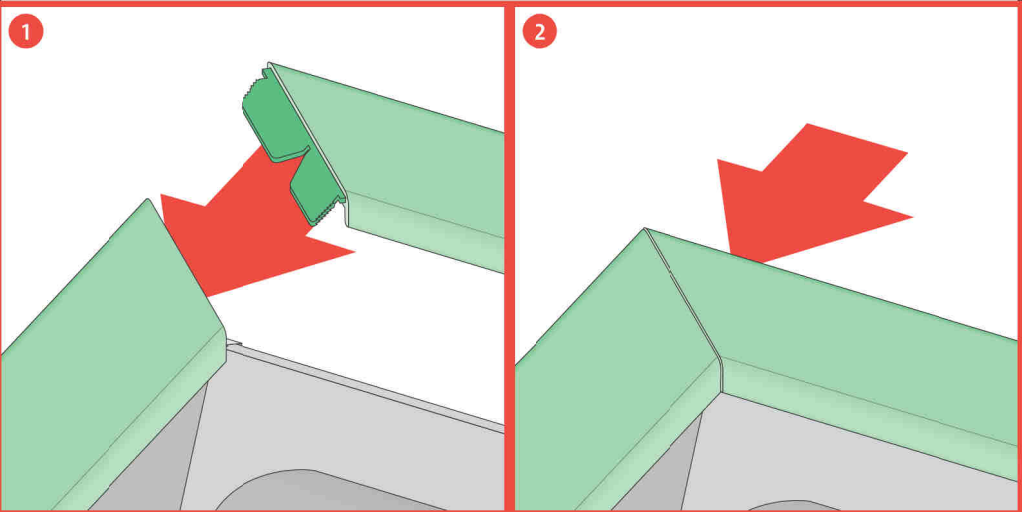
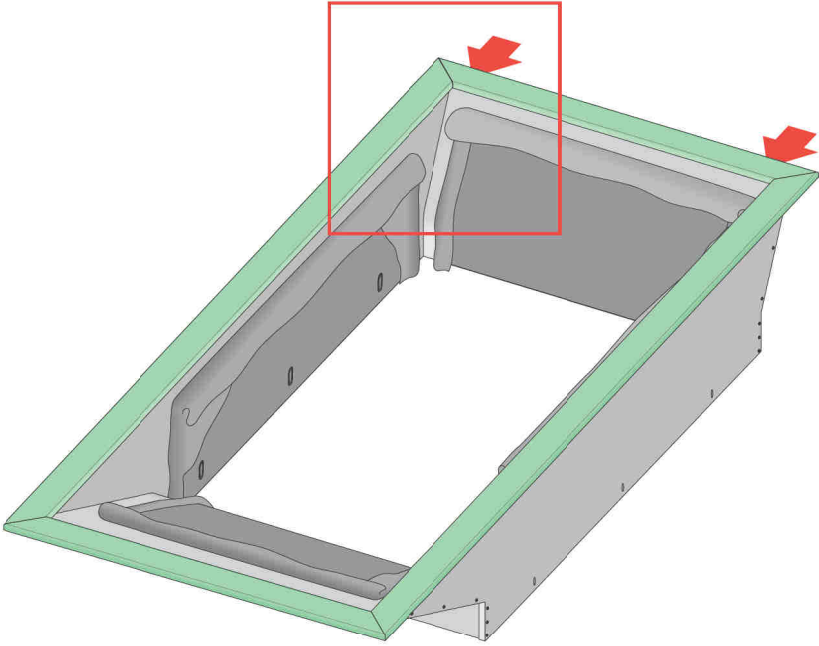

10h

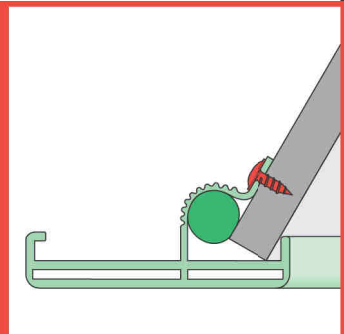
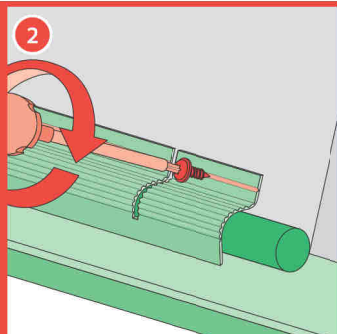
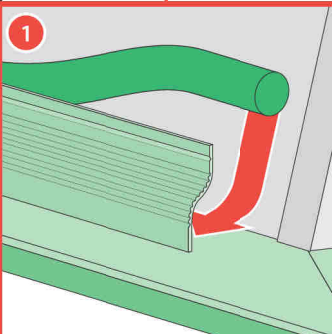
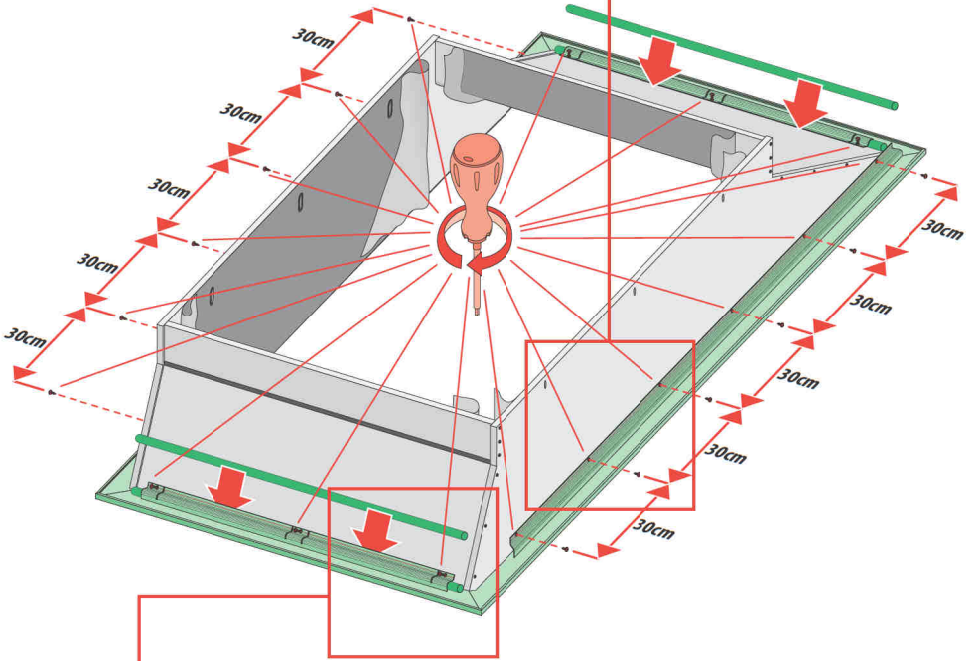
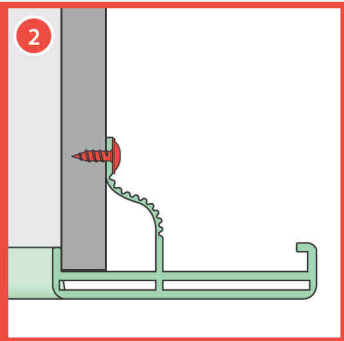
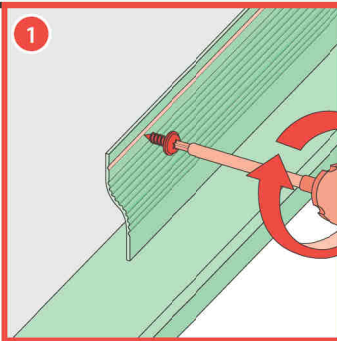

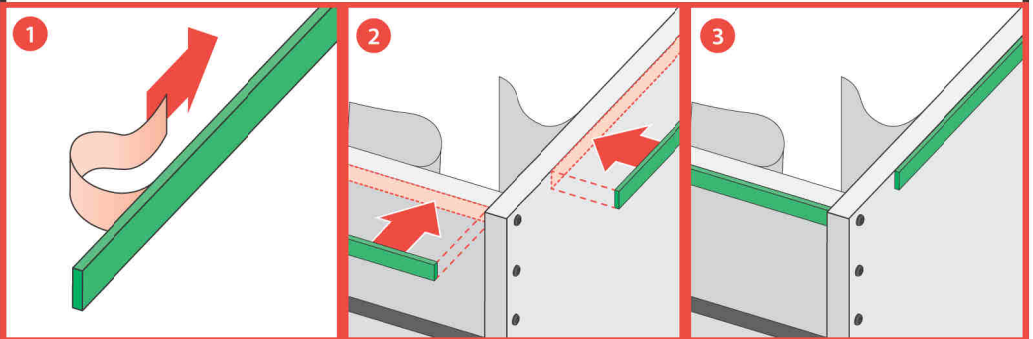
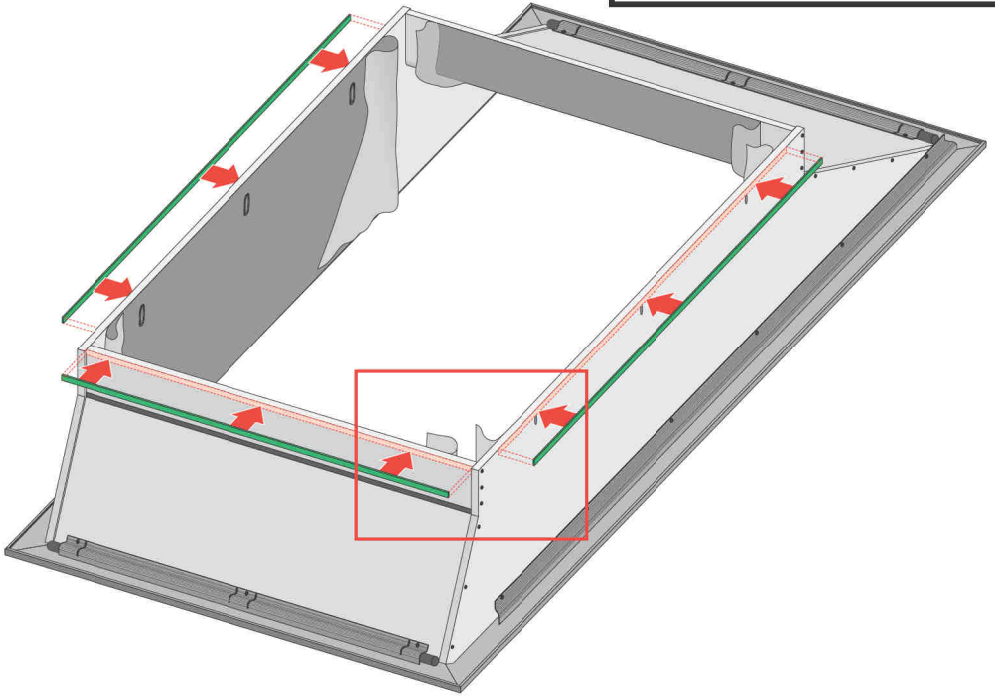
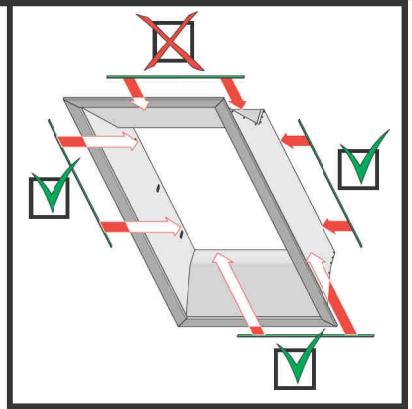

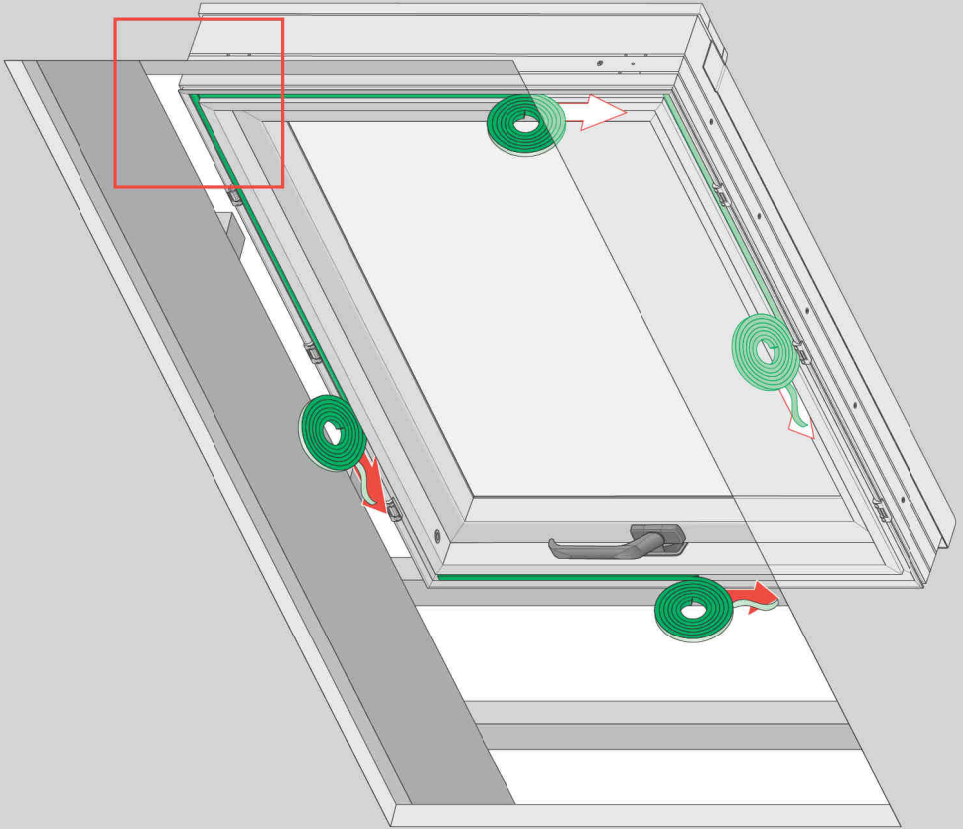

1

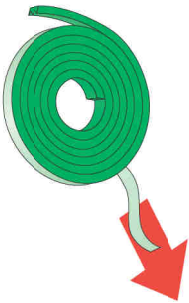

2

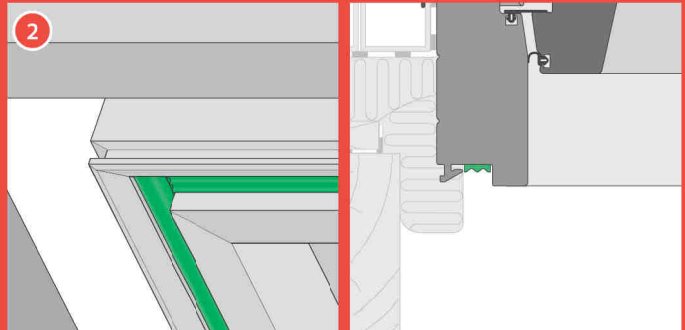

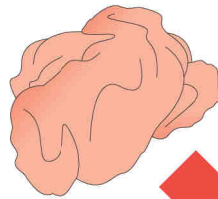
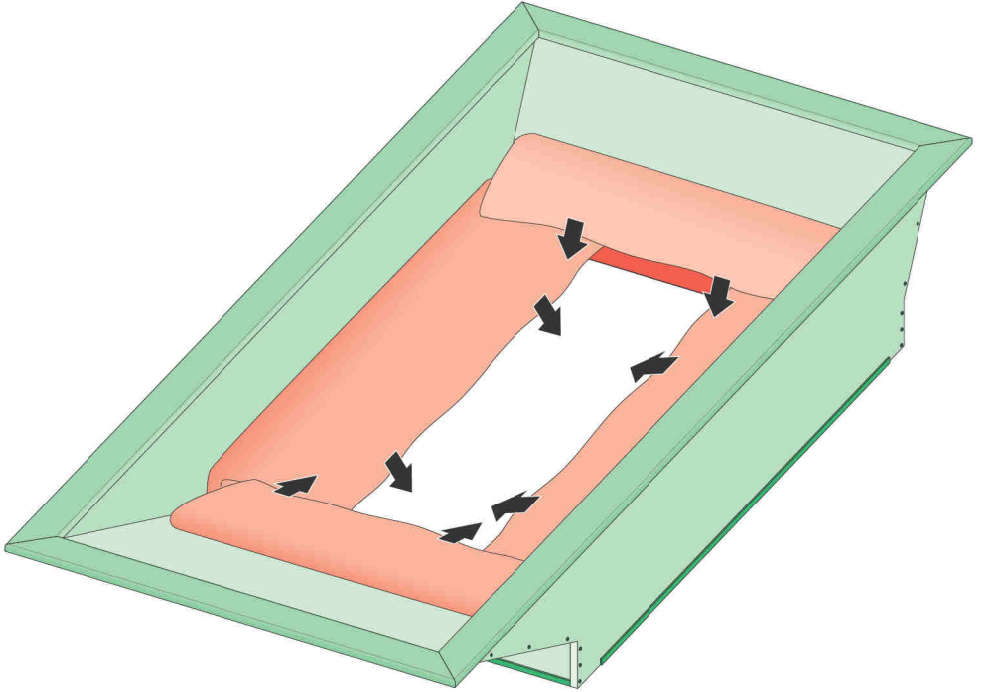

14a

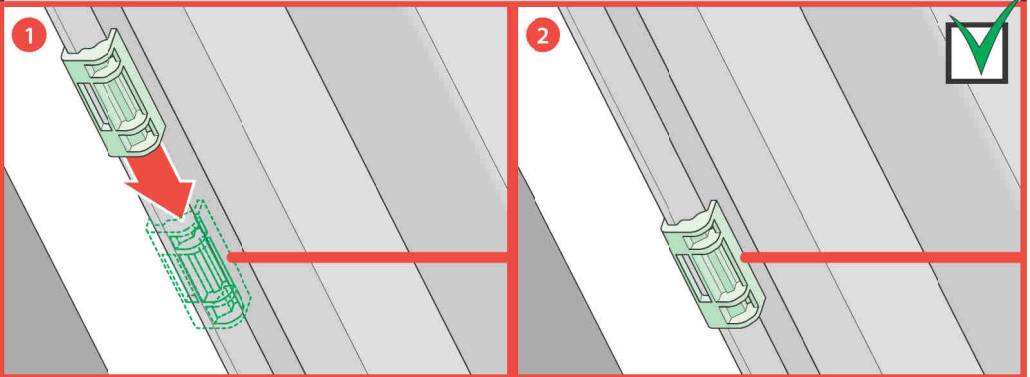
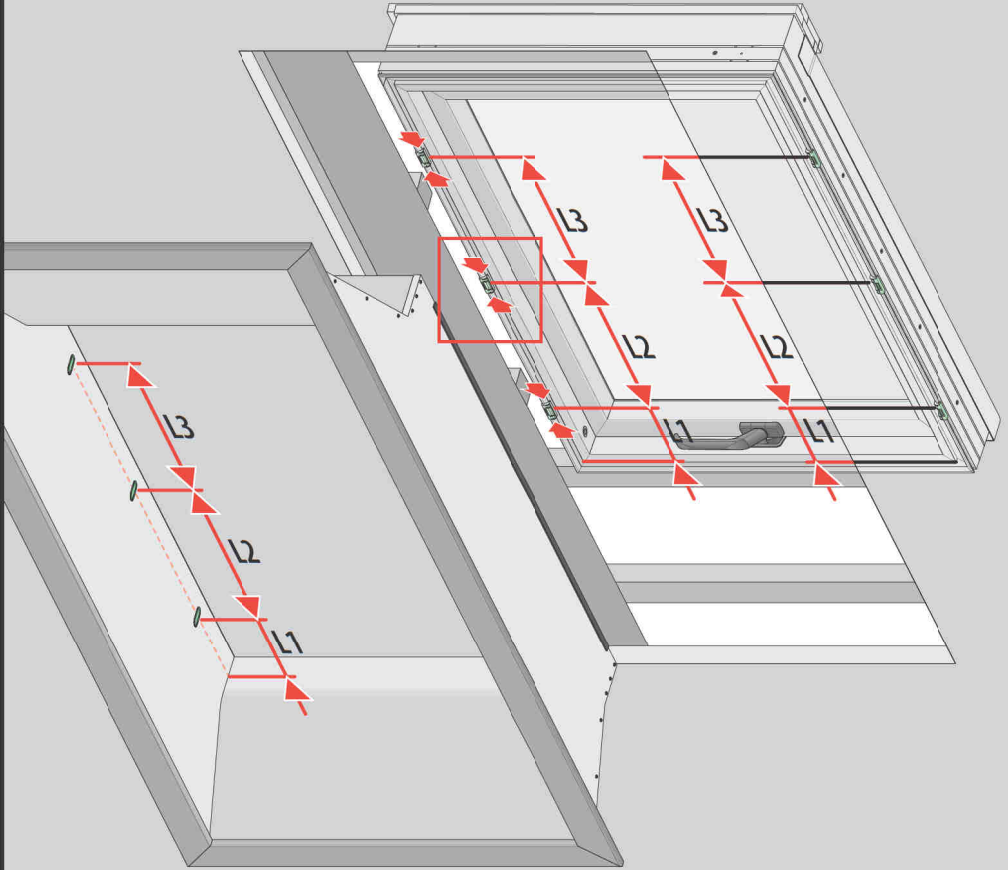

14b

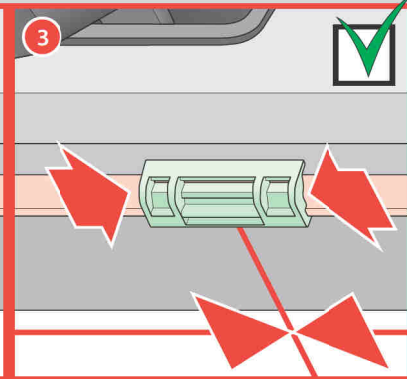
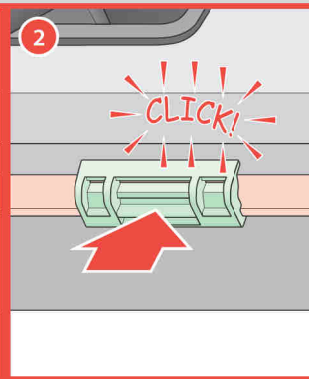
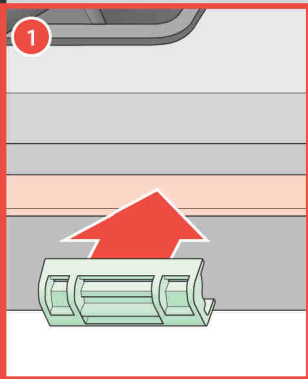
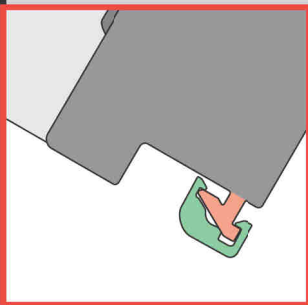
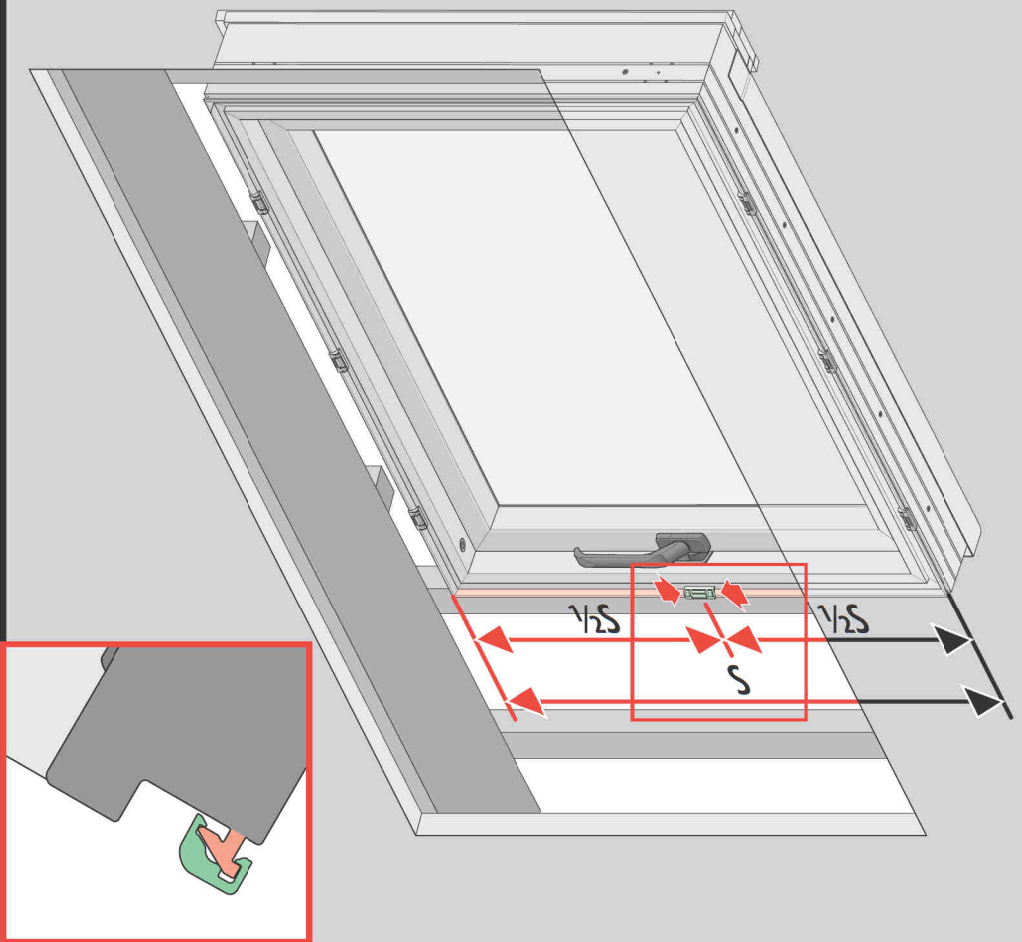

14c

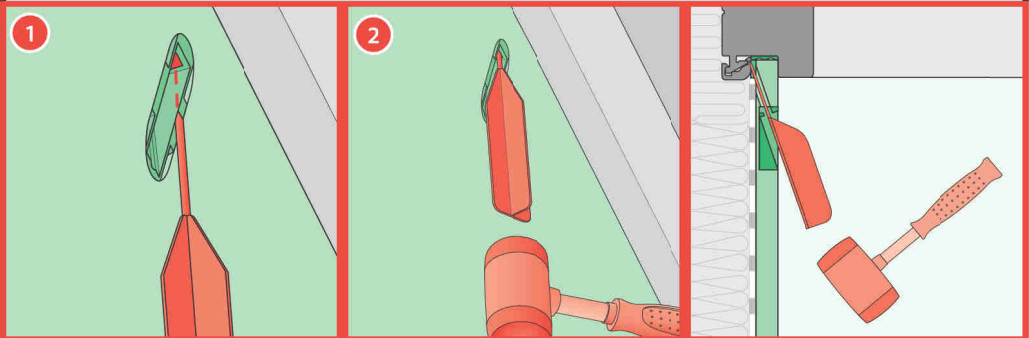
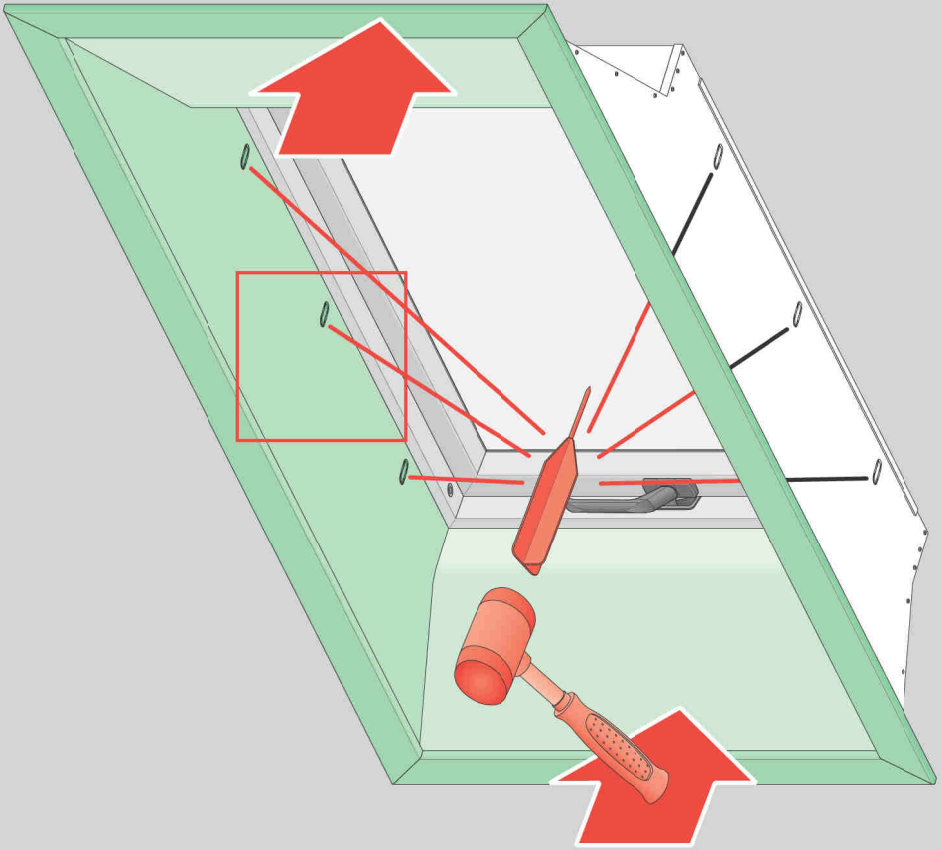
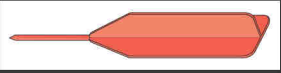

14d

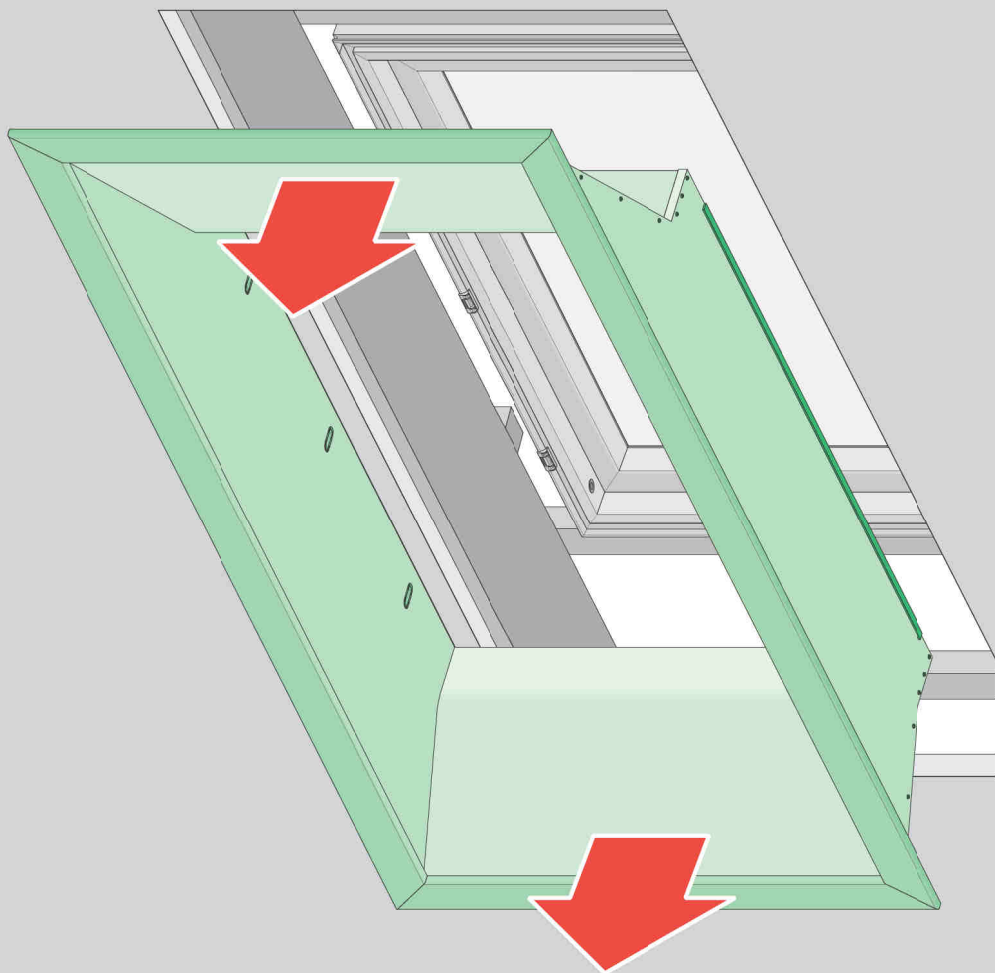

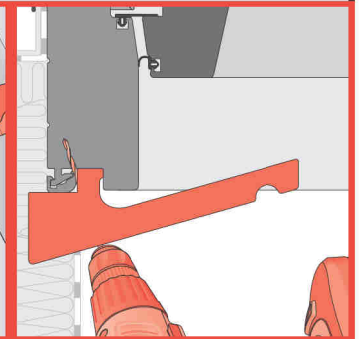
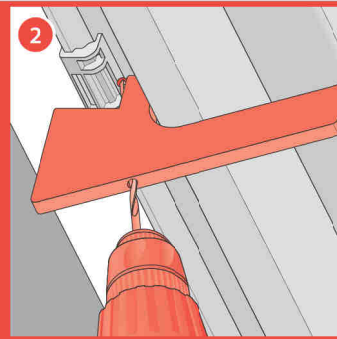
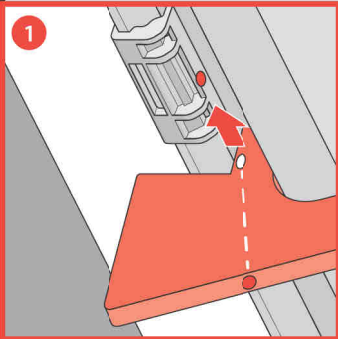
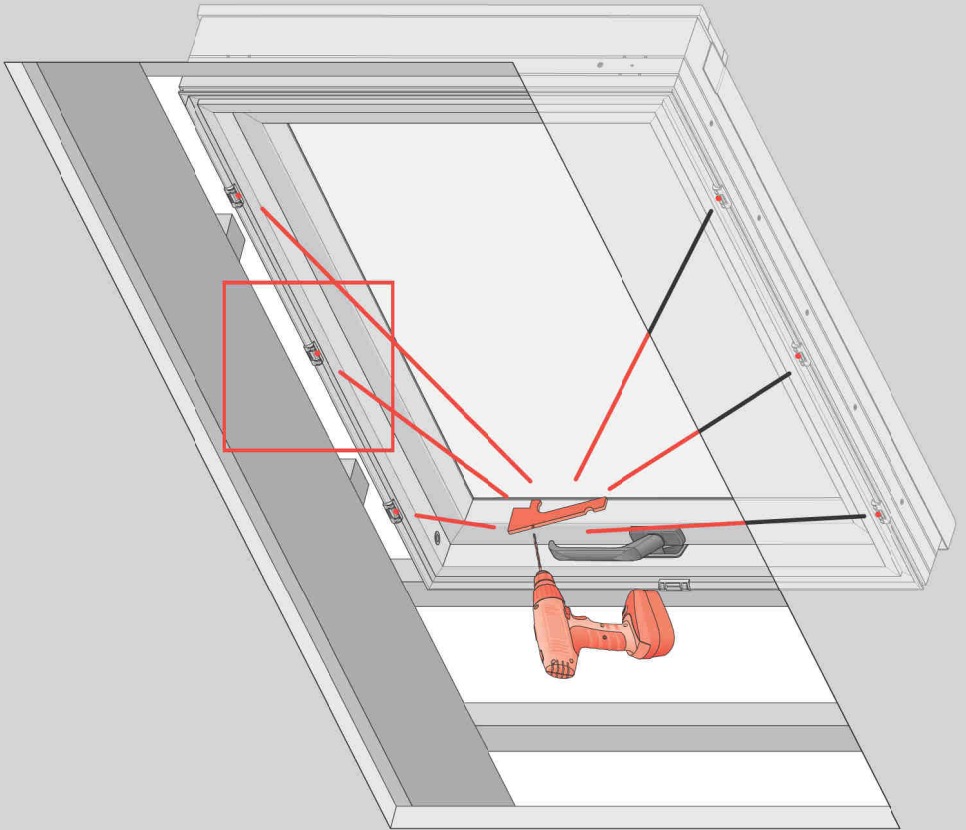

14f

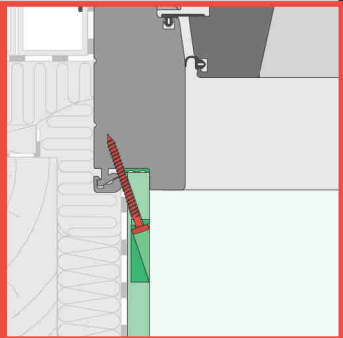
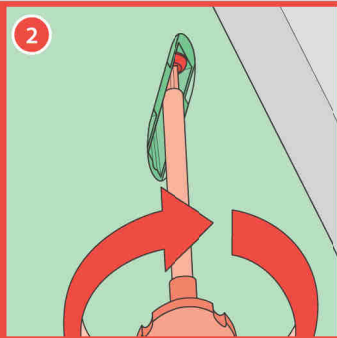
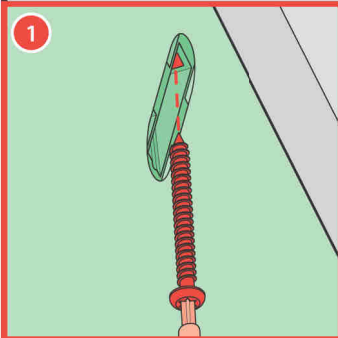
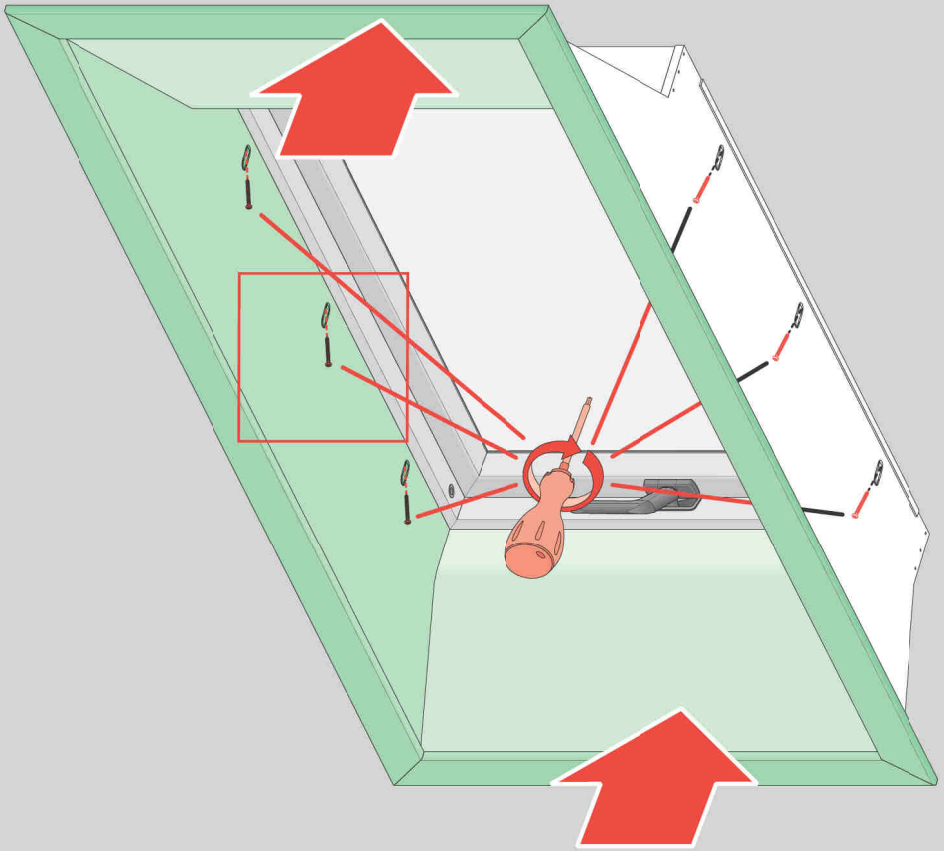
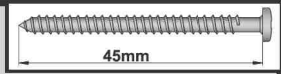

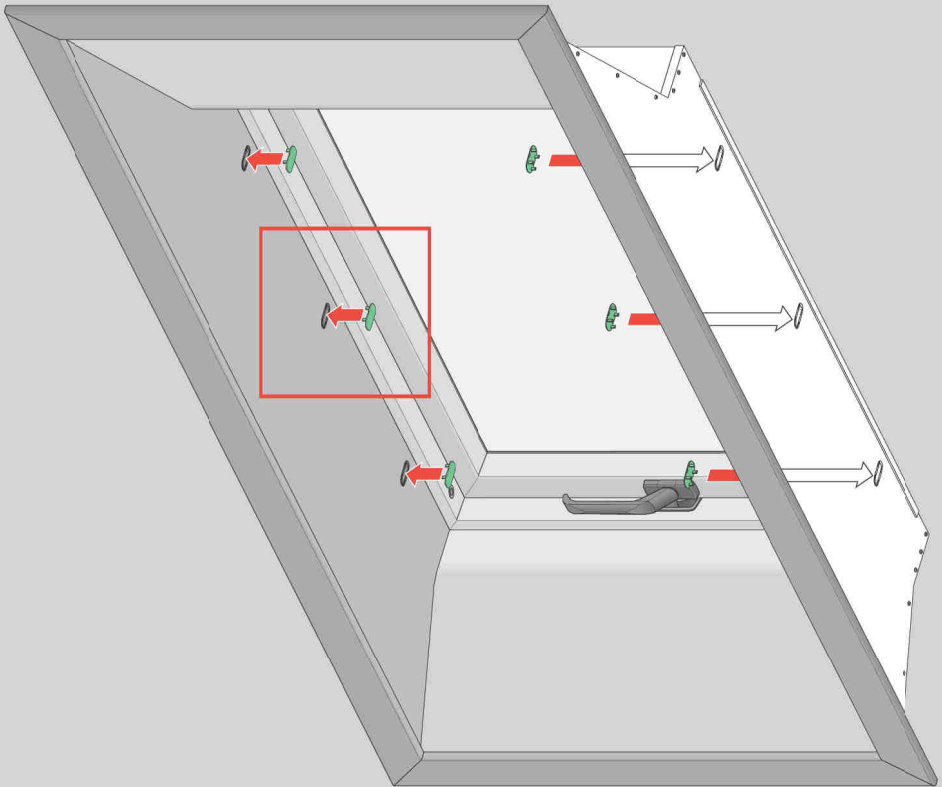

1

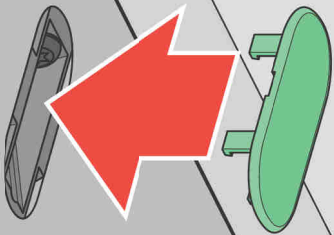

2

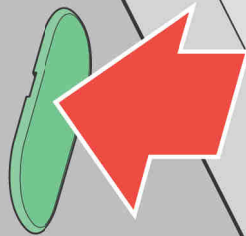

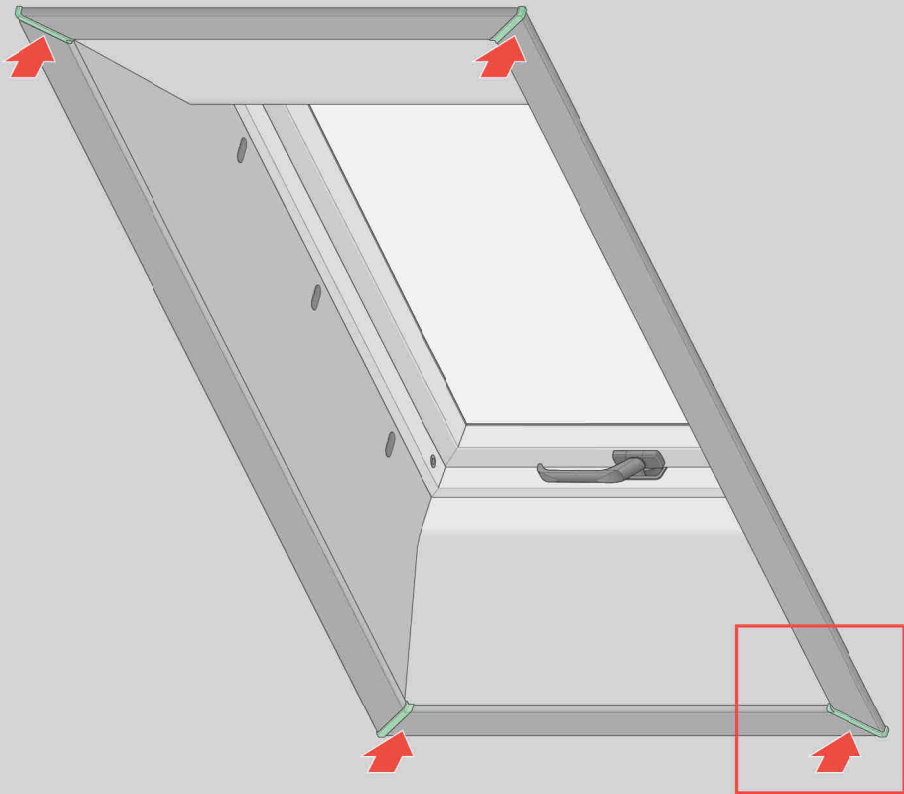

0 [cm] 1 2 3 4 5 6 7 8 9 10 11 12

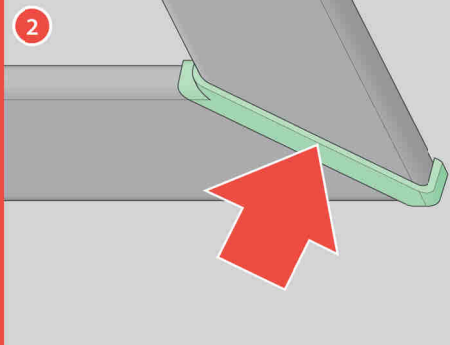
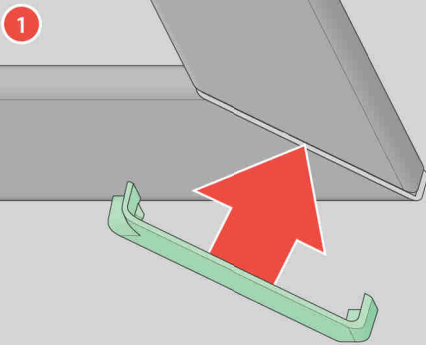

BG	Производител и Продавач не носят отговорност за неспазване на съответните закони, строителни норми и киеввания за безопасност от употребяване на продукта на, архитекта, монтажника или собственика на сградата.
CZ	Výrobce ani prodejce nenesou žádnou odpovědnost za neudržení příslušných právních zákonů, stavebních předpisů a bezpečnostních požadavků uživatelem výrobku, architektem, montážníkem nebo vlastníkem budovy.
DE	Hersteller und Verkäufer übernehmen keine Haftung für Nichtbeachtung entsprechender Rechts- und Bauvorschriften sowie Sicherheitsanforderungen seitens Produktbenutzers, Architekten, Monteure oder Gebäudebesitzers.
EE	Tootaja ja müüja ei vastuta toote kasutamise, arhitekti, paigaldaja või hoonde omaniku poolt kehtivate seaduste, määruste ja ohutusnõuete mittejärgimise eest.
ES	El fabricante y el vendedor no tienen ninguna responsabilidad por el incumplimiento de la ley vigente, normas de construcción y exigencias de seguridad por parte del usuario del producto, arquitecto, instalador o el propietario del edificio.
FR	Le fabricant et le vendeur ne prend aucune responsabilité de ne pas respecter les lois applicables, les règlements sur les bâtiments et les exigences de sécurité par l'utilisateur du produit, l'architecte, l'installateur ou le propriétaire du bâtiment.
GB	Manufacturer and Seller shall bear no liability for failure to comply with the applicable laws, building codes and safety requirements by the user of the product, architect, fitter or owner of the building.
HU	A gyártó és a forgalmazó nem vállal semmiféle felelősséget a vonatkozó törvényi, építési és biztonsági előírások nem megfelelő használatáért, építész, beépítőmester vagy épülettulajdonos által be nem tartásáért.
IT	Il Produttore e il Rivenditore non potranno essere ritenuti responsabili per il mancato rispetto da parte dell'utente del prodotto, dell'architetto, dell'installatore e del proprietario dell'edificio, delle leggi vigenti, nonché dei regolamenti edilizi e di quelli relativi alla sicurezza.

LT	Gaminiojas ir pardavėjas neprisiima jokios atsakomybės už tai, kad gamintojas, architektas, montuotojas ar pastato savininkas nesilaiko galiojančiu statybinio, statybos ar saugos reikalavimu.
LV	Kārtājs un mazumtirdzības tirdzniecības atbildotājs par likumu, noteikumu un drošības prasību neievērošanu, no produkta lietotāja, arhitekta, uzstādītāja vai ēkas īpašnieka puses.
NL	De fabrikant en verkoper zijn niet aansprakelijk voor gevolgen bij het niet opvolgen van toepasselijke wetten, bouwbesluiten en veiligheidsvoorschriften door de gebruiker van het product, de architect, de installateur of de eigenaar van het gebouw.
PL	Producent i Sprzedawca nie ponosi żadnej odpowiedzialności za nieprzestrzeganie stosownych przepisów prawa, przepisów budowlanych i wymogów bezpieczeństwa przez użytkownika produktu, architekta, montażystę lub właściciela budynku.
PT	O fabricante e o vendedor não tem nenhuma responsabilidade pelo o não cumprimento da lei, códigos de construção e as exigências de segurança por parte do usuário do produto, arquiteto, instalador ou proprietário do edifício.
RO	Nici producătorul, nici distribuitorul nu își vor asuma niciun fel de răspundere pentru nerespectarea legilor în vigoare, a legilor din domeniul construcțiilor sau a măsurilor de siguranță impuse utilizării produsului, arhitectului, montajului sau proprietarilor clădirii.
SI	Proizvajalec in prodajalec ne prevzemata odgovornosti za neupoštevanje ustreznih pravnih in gradbenih predpisov ter varnostnih zahtev s strani uporabnika izdelka, projektanta, montažerja ali lastnika objekta.
SK	Výrobca a predajca nenesú žiadnu zodpovednosť za neudržanie príslušných ustanovení zákona, stavebných predpisov a bezpečnostných požiadaviek užívateľom výrobku, architektom, montážnym alebo majiteľom objektu.